



**AMPTEC RESEARCH
MODEL 620VL OPERATION AND
MAINTENANCE MANUAL**

A MESSAGE FROM THE PRESIDENT



We at AMPTEC RESEARCH would like to thank you, our customer, for selecting our Failsafe Igniter Tester/ Digital Ohmmeter. Over the past 36 years our experienced engineering staff have designed, manufactured and supplied earlier versions similar to the Model 620 and 620 Series Igniter Testers to the U.S. NAVY for the "TOMAHAWK CRUISE MISSILE", the U.S. ARMY for the "STANDARD MISSILE", the U.S.A.F. for the AIM-9 "SIDEWINDER", AIM-7 "SPARROW" and AIM-120 "AMRAAM" just to name just a few. We value the trust our customers have placed with us, and are looking forward to supporting any new requirement you may have

Kerry Clark - President AMPTEC RESEARCH

U.S. N.I.S.T. CALIBRATION CERTIFICATE



AMPTEC RESEARCH, Inc. certifies that this instrument has been completely tested and inspected and found to meet published specifications as found in this manual on the date stated on the attached N.I.S.T. Certificate. AMPTEC RESEARCH, Corporation further certifies that its calibration measurements are traceable to the U.S. National Institute of Standards and Technology.

620 SERIES VL-T IGNITER TESTER WARRANTY



Permission and a return authorization (RMA) number must be obtained directly from AMPTEC's customer service department (via phone, FAX, or email) for repairs (warranty or otherwise). We need to issue you an RMA number so we can keep track of the instrument and it's owner (i.e. who to contact). The warranty period for this instrument is 1 year from when it was first shipped. AMPTEC RESEARCH will repair or replace the instrument during the warranty period provided it is returned to AMPTEC RESEARCH, freight prepaid. No other warranty is expressed or implied. We are not liable for consequential damages. No liability will be accepted if returned without such permission.

Some AMPTEC products may have their design frozen, and no changes will be made without prior notice to the proper approving authority. Through out this manual, there is reference made using to the generic model 620 series Igniter Testers. There are any versions of the 620 Igniter Tester specifically developed to meet our customers requirements. The specification, operation, drawing and schematic sections of this manual contain the unique detail that define the 620VL Due to continuing product refinement, due to possible parts going obsolete and other component manufacturer changes, AMPTEC RESEARCH reserves the right on rare occasions to change any of its products specifications.

TABLE OF CONTENTS

SECTION A: RECEIVING AND INITIAL INSPECTION

- A-1 Introduction to the AMPTEC 620VL series
- A-2 Unpacking and Inspection
- A-3 Isolated AC/DC Adaptor to DC/DC Converter- Power Requirements
- A-4 Setup and Use



SECTION B: 620VL FAILSAFE OHMMETER SPECIFICATIONS

- B-1 Specifications



SECTION C: REPLACEMENT, OPTIONAL AND ACCESSORY ITEMS

- C-1 Available Accessories and Options
- C-2 Test Lead Sets



SECTION D: OPERATION, FUNCTION AND USE

- D-1 General
- D-2 Front Panel
- D-3 4-Wire Resistance Measurement
- D-4 Connections
- D-5 Failsafe Operation
- D-6 Battery Monitoring Circuitry



Figure D-1 Error sources in Resistance Measurements

SECTION E: GENERAL OPERATION AND DESIGN

- E-1 General
- E-2 Troubleshooting
- E-3 Circuit Descriptions
- E-4 Analog-to-Digital Converter
- E-5 Ohms-to-DC Converter



- E-6 Failsafe Design
- E-7 Ultra-Safe Power Supply Scheme

- Figure E-1. Model 620VL Block Diagram
- Figure E-1B Analog-to-Digital Converter Timing Diagram
- Figure E-2 Analog Section of IC1 and IC2
- Figure E-3. Constant Current Source Diagram (Simplified)
- Figure E-4. LED Display Pin Functions

SECTION F: ROUTINE MAINTENANCE

- F-1 General
- F-2 Required Test Equipment
- F-3 Calibration Procedure
- F-4 Battery Replacement Instructions

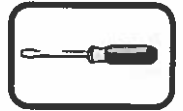

SECTION G: COMPONENT PARTS LISTS

620-400 Parts/Assembly list

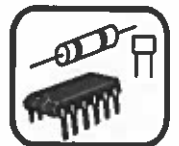

SECTION H: SCHEMATICS AND DIAGRAMS

- Drawing 620VL -070 620VL Main PCB Electrical Schematics
(Rev E Main PCB) {640SL Explosive Safety Meter-070 DVM1 - 1 of 2
and 620VL-070 Current (I source - 2 of 2) Source}
- 620VL Main PCB Bill Of Materials (components parts list) page 1 of 2
- 620VL Main PCB Bill Of Materials (components parts list) page 2 of 2
- Drawing 620VL-600 620VL Main PCB Assembly (*Silkscreen Ref. Design Dwg.*) rev. J
- Drawing 620VL-RS232 620VL Rear Panel Diagram
- Drawing RS232C Controller PCB Schematic (page 1 of 3 pages)
- Drawing RS232C Controller PCB Schematic (page 2 of 3 pages)
- Drawing RS232C Controller PCB Schematic (page 3 of 3 pages)
- 620VL (sample) Quality Inspection Test Report

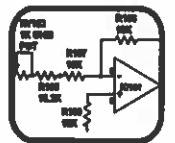

SECTION A - RECEIVING AND INITIAL INSPECTION

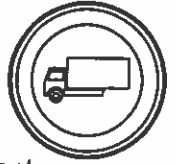

A-1. Introduction to the AMPTEC 620VL

The AMPTEC 630, 640 and now the 620 Series Igniter Testers/Failsafe Ohmmeters are becoming the standard in the Safety Igniter Circuit Test industry, and are designed to provide extremely safe and reliable resistance testing of explosive or volatile devices. Safety Approvals from various Safety Boards include, the U.S. Air Force (620A-4) for generic use on Non-Nuclear munitions and the US NAVAL ORDNANCE CENTER (620AN and other versions pending). Some of the devices the 620VL Igniter Tester may be used on include: fuses, squibs, igniters, explosive bolts, rocket motor squibs, automobile air-bag initiators and many others.

The AMPTEC 620VL is a 4-wire failsafe digital ohmmeter which has been designed to reliably use very low test currents for its resistance measurement. Failsafe Output Circuitry proprietary to AMPTEC RESEARCH ensures that test current levels do not exceed the specified "failsafe current" even in a worst-case component failure situation. The failsafe feature is tested in every instrument before shipment.

The newer 620 series represent the latest in ultra-safe Igniter Tester measurements. The 620VL uses the same main printed circuit board (PCB) as all of the AMPTEC 620A Igniter Testers. The 620VL has many features which make it useful in a variety of applications. Please check the last chapter of this manual for addendums that may apply to the AMPTEC 620VL.

As a safety precaution, the AMPTEC 620VL Explosive Safety Igniter Tester is always electrically isolated (to 3KV) from the AC line regardless of whether the unit's power switch is "ON" or "OFF". The AMPTEC 620VL Explosive Safety Igniter Tester uses the DC voltage (~24 VDC) supplied by the AC/DC Adapter then internally filters, converts and isolates it. The AC/DC Adapter (~24 VDC) supply is converted to 5.0 VDC and is also isolated to 3,000 Volts via a medical grade 3.0 KV DC to DC convertor. The 3.0 KV isolation

provides a large safety margin or barrier between the AC/DC Adapter DC supply and the unit's measurement electronics. The unit's medical grade 3.0 KV DC/DC line isolation barrier is independent of the unit's RS232C interface electrical isolation. A surge suppressor may also be used to provide an additional margin of safety in event of lightning or line spikes.

A-2. Receiving, Unpacking and Initial Inspection

Should the AMPTEC shipping box appear damaged upon arrival, request that the carrier's agent (i.e. UPS) be present when the unit is unpacked. If the 620VL appears damaged, the carrier's agent should authorize repairs before the unit is returned to the factory. Even if the instrument appears undamaged, it may have suffered internal damage in transit that may not be evident until the unit is operated or tested to verify conformance with its specifications.

If the unit fails to operate or fails to meet the performance specifications of Section B, notify the carrier's agent and the nearest AMPTEC Sales Office. Retain the shipping carton for the carrier's inspection. **DO NOT return equipment to AMPTEC RESEARCH** or any of its sales offices *without first obtaining an (RMA) Return Material Authorization number.* We need to know who to contact and how to contact (i.e. phone number and FAX number) in order to properly coordinate the return of the repaired AMPTEC product.



By calling AMPTEC RESEARCH first, prior to just returning the 620VL, we can often troubleshoot (based on the symptoms you describe) and identify the problem over the phone (i.e battery loose in the battery holder).

We may possibly be able to fix the problem over the phone and prevent you from having to return the unit to AMPTEC for repair.

Sect. A - Receiving and Initial Inspection

A-3. Isolated AC/DC Adaptor to DC/DC Converter- Power Requirements

Internally, the AMPTEC 620VL's is powered with the DC supply coming from an external AC to DC adapter plugged into the DC jack on the unit's rear panel. The option "620VL/DC" supply comes with each AMPTEC 620VL Igniter Circuit Tester in order to allow it to run continuously 24 hours a day 7 days a week. As a safety precaution, the AMPTEC 620VL Explosive Safety Igniter Tester is internally (DC/DC converter - inside the black box assembly mounted on the unit's bottom plate) always electrically isolated from the AC line (to 3 KV) whenever the unit's power switch is "ON" or "OFF". The AMPTEC 620VL Explosive Safety Igniter Tester does not use or need any "D" cell NICAD battery packs of any type to continually power the unit.

As a safety precaution, the AMPTEC 620VL Explosive Safety Igniter Tester is always electrically isolated (to 3KV) from the AC line regardless of whether the unit's power switch is "ON" or "OFF". The AMPTEC 620VL Explosive Safety Igniter Tester uses the DC

voltage (~24 VDC) supplied by the AC/DC Adapter then internally filters, converts and isolates it. The AC/DC Adapter (24 VDC) supply is converted to 5.0 VDC and is also isolates the unit to 3,000 Volts via a 3.0 KV DC to DC converter.

The 3.0 KV isolation provides a large safety margin or barrier between the AC/DC Adapter and the unit's measurement electronics. The unit's 3.0 KV line isolation barrier is independent of the unit's RS232C interface electrical isolation.

The units power supply is an external AC/DC converter that plugs into a standard 115VAC receptacle.

The units AC/DC *adapter* must be plugged into the 620VL's rear panel to facilitate *operating* the AMPTEC 620VL 24 Hrs/Day *continually* . The *adapter* should always be plugged into the unit's charging jack as the AMPTEC 620VL is always electrically isolated from the AC/DC charger.

A-4. Setup and Use

The AMPTEC 620VL Igniter Tester may be setup to operate within minute(s) of power "turn on" (unless your in an extremely cold temperature - allow more time for warm-up - 15 minutes). A quick test lead integrity check and it should be ready to use.

Avoid exposing the AMPTEC 620VL Igniter Tester to extremes of temperature which will affect accuracy.

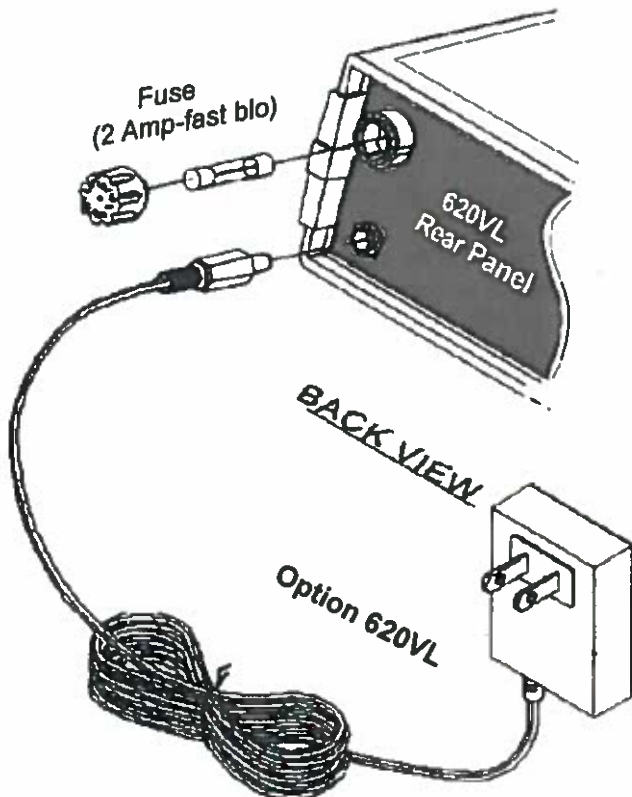

**SECTION B - 620VL EXPLOSIVE SAFETY
IGNITER TESTER - SPECIFICATIONS**



2.0K Ω	20K Ω	200K Ω	2.0M Ω
50 μ A	5 μ A	0.5 μ A	.05 μ A
150 μ A	15 μ A	1.5 μ A	.15 μ A

620VL Resistance Range / Display Resolution Table

Diode Test (Voltage Forward) Test Current Levels - 0.5mA/<25ma Fail-Safe

Actual fail-safe currents vary with each instrument and may be $\pm 20\%$ from the typical value.

Table B-1 Specifications

Accuracy: (for 1 year @25°C $\pm 10^\circ$ C)

2.0K Ohm - 20K Ohm ranges $\pm 0.02\%$ of reading $\pm 0.05\%$ of range

20K Ohm - 200K Ohm ranges $\pm 0.05\%$ of reading $\pm 0.05\%$ of range

200K Ohm - 2.0 M Ohm ranges..... $\pm 1.0\%$ of reading $\pm 0.2\%$ of range

Temperature Range

Operating 0°C to 50°C

Storage -10°C to 70°C

Temperature Coefficient

20 Ω through 200 Ω ranges $\pm 0.002\%$ per °C (from 0°C-15EC and 35°C-50°C)

2.0 M Ω range $\pm 0.01\%$ per °C (from 0°C-15EC and 35°C-50°C)

Instrument Display .. (20,000 count) 4½ digit Super Bright Light Emitting Diodes (LED)

Over-Range Indication (select next higher range) 620VL Display flashes

Measurement Update Rate Approximately 300ms

Voltage Protection - Maximum Input 250VDC or AC_{peak} without damage

Open Circuit Current Source Compliance Voltage clamped at ~1.6 volts

AC/DC Power Adapter (Option 620VL-DC) provides 24VDC at 0.5 Amperes nominal

Dimensions 9.0" (23cm) W x 9.0" (23cm) D x 3.0" (8cm) H

Weight 4 lbs net; 10 lbs shipping (without transit case)



SECTION C - REPLACEMENT, OPTIONAL AND ACCESSORY ITEMS



C-1. Available Accessories and Options

Listed below are the options available for use with the AMPTEC 620A Series FailSafe Ohmmeters.

Option "620RC/DC": Slimline Battery Charger

Option "620RC/DC" is the AC/DC converter that *supplies basic DC power (i.e 24 VDC) to the unit's internal DC to DC convertor.* Only the AMPTEC 620VL/DC power adapter should be used to continually operate the AMPTEC 620VL Explosive Safety Igniter Tester 24 Hrs/Day (*any other NON-AMPTEC DC adapter substitute may be unsafe and violate warranty*). A 220 VAC 50 Hz powered Power Adapter is also available from AMPTEC RESEARCH.

Option 100: Carrying Case

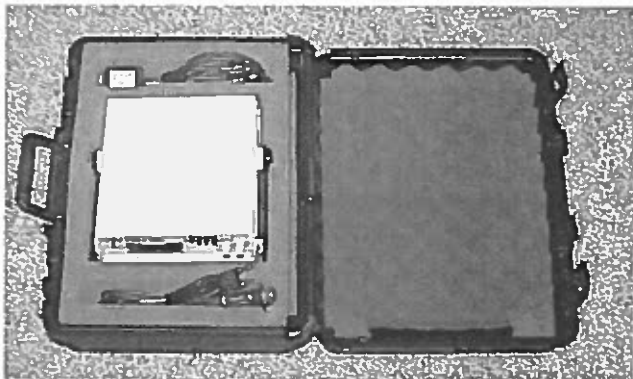

Option "100" is a hardshell (impact resistant plastic) shock absorbing foam lined meter and accessory carrying case for the 620A Ohmmeter with extra room for test leads, battery charger, Kelvin Clip Test Leads, Connector Adapters, single pointed probes and operator manual etc.

Option RACK: Rack Mount Adapter

Option "620RACK" includes an adapter tray that allows any AMPTEC 620 series tester to be flush panel mount installed in a standard 19" equipment rack.

C-2. Test Lead Sets and Probes

Option "290" Alligator Clip Lead Set

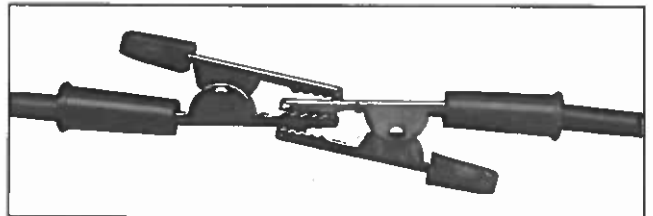

Option "290" is the recommended general purpose Alligator Clip test lead set (red and black) *for models not having a 2.0 Ohm range* (due to a small resistance "offset" at the tips - OK for 20 Ohm and higher range units). Option "290" is supplied as a standard item with all 620A-4 (USAF version) ohmmeters as part of the accessory package. Option "290" is a 48" long cable set with dual banana plugs at one end. The other end is terminated with an alligator clip (red and black). Some "Squib Resistance" test panel jacks have a plastic exterior with a conductive socket center. These alligator clips will measure (2 wire method) properly with either upper or lower jaw connected to the conductive socket center of plastic test panel jacks. Kelvin Clips see Option "300" (using the 4 wire method) *may have difficulty only if both jaws (both upper and lower) do not make electrical contact with the conductive "resistance under test" center.*

See next page for Kelvin Clips and other accessories.

Sect. C - Replacement, Optional and Accessories Items

Option 300: 4-Wire Gold Plated Kelvin Lead Set

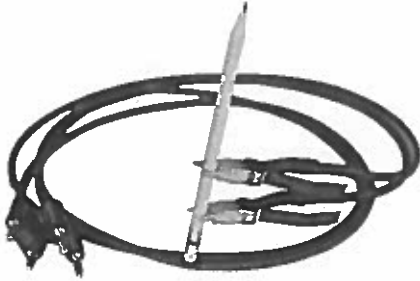

Option "300" is a general purpose Gold Plated Kelvin four wire Leads for all AMPTEC 620 series Testers. Gold plated kelvin clips provide a low thermal EMF connection (minimizes the thermocouple effect) with most connections. *The Option "300" is the recommended test lead set for any AMPTEC Igniter Testers with a 2.0 Ohm range* (i.e models 630ES and 620VL). The 4 wire Kelvin connection is *important when measuring less than 1.0 ohm*, and also automatically *eliminates test lead length offset and test lead contact resistance errors*. Option "300" is a shielded 48" lead set terminated in 1/2" opening gold plated Kelvin clips. The option "300" can clip easily to wires, pins, and medium size (up to 1/2" diameter conductors). The dual banana plug ends connect directly to the 620 tester's front panel input terminals. (see Option "320" for replacement Kelvin clip ends only)

Option 305: Banana-to-Banana Cable

Option "305" is a 48" shielded cable terminated in dual banana plugs at both ends.

Option 320: Kelvin Clips

Option "320" are the gold plated kelvin clips used on the Option "300" cable set . These clips may be used when making custom cables or when repairing Option "300".

Option 360: Heavy-Duty Clips

Option "360" are Gold-plated jumper cable (large jaws) type clips used on the Option "350" cable. They are still Kelvin Clips because the insulated upper and lower jaw (jumper cable appearance) integrity is maintained. These may be used when making custom heavy duty cables that open to 1 1/2 " wide (i.e bolt heads)..

Option 401: Handheld Single Probe Leads

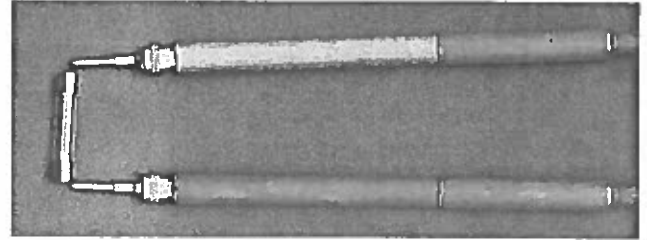

Option "401" is a 620 series compatible handheld probe (one black probe & one red probe) lead set terminated in *single points*. The OP401 handheld probes allow for easy access to connector socket wiring (i.e. drone parachute squib sockets), recessed surfaces, and parts (i.e. flares) that alligator clip leads simply would not work well with.

Option "500" Optically Isolated Analog Output

This rear panel mounted isolated analog DC Voltage output signal is directly proportional to the 620 tester's ohm display measurement. (i.e. 1.2345 VDC for 12.345 ohms). It is used to track 620 tester measurements for datalogging purposes with an external device (i.e chart recorder, system DMM with GPIB). Isolation protection is rated @2000 volts peak to insure any instrument connected to "Option 500" has virtually no impact on the 620 series tester's safety.

Option "600" Optically Isolated Binary Coded Decimal (BCD) Data Output

For applications requiring data output the 620 series is available with "BCD" output. The measured resistance readings are output via a rear panel "BCD" talk only interface. A High-Go- Low BCD Dual Limit Comparator is presently under development and will be available Summer of 2001..

New Options and Custom Leads Available

Contact the sales department at AMPTEC RESEARCH (phone 1-800-350-5105) if you have need for GPIB, a special probe, adapter, lead set, or custom option not listed in this manual. AMPTEC'S experienced application engineers have helped supply many customers with special igniter tester accessory requirements.

Sect. C - Replacement, Optional and Accessories Items

Functional Test Section - The optional 620VL Functional Test Box provides added measurement integrity using a milliammeter and test resistors to cross check the overall 620VL operation whenever desired. The test resistors are for cross checking 620VL basic operation and should not be used for Calibration purposes.

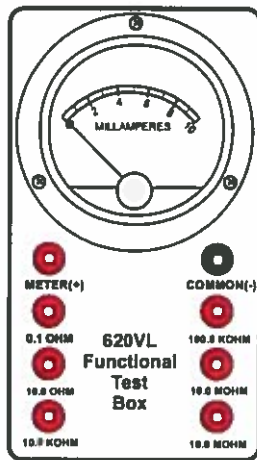

Simpsontm DC Milliammeter Range
0-10 mA fullscale, Accuracy $\pm 3\%$

FTSR1	01-23572	0.1 Ω	1.0 % Resistor, Tc- 25ppm/ $^{\circ}$ C, $\frac{1}{4}$ W
FTSR2	01-23575	10.0 Ω	< 0.1% Resistor, Tc- 10ppm/ $^{\circ}$ C , $\frac{1}{4}$ W
FTSR3	01-23577	10.0 K Ω	<0.1% Resistor, Tc- 10ppm/ $^{\circ}$ C, $\frac{1}{4}$ W
FTSR4	01-23583	100 K Ω	<0.1% Resistor, Tc- 10ppm/ $^{\circ}$ C, $\frac{1}{4}$ W
FTSR5	01-23587	10.0 M Ω	<1.0% Resistor, Tc- 20ppm/ $^{\circ}$ C, $\frac{1}{4}$ W
FTSR6	01-23589	19.0 M Ω	<1.0% Resistor, Tc- 50ppm/ $^{\circ}$ C , $\frac{1}{4}$ W



SECTION D - OPERATION, FUNCTIONAL SELF - TEST AND USE

D-1. General Operation

This section contains operating instructions for the AMPTEC 620VL Explosive Safety Igniter Tester.

D-2. Front Panel Features and Operation



When the front panel power switch is in the "OFF" position, all power is removed from the unit's main PCB and the unit's RS232C interface. When the 620VL main power switch is placed in the power "ON" position, the unit powers up all ohms measurement circuitry and allows the optically RS232C interface located on the unit's rear panel to operate remotely. For continuous (24 Hr/7day) use keep the AC/DC adapter plugged in the unit's rear panel charging jack (Internally Safety Isolated to 3 KV).

Display "OFF" - Saves Battery Consumption

The AMPTEC 620VL originally had a display "On Off switch" (*now removed*) to help reduce power consumption may be ~30 % by turning off the unit's LED display. Originally the unit *was* to be battery powered and operate in the remote RS232C control and reading mode 24 Hours a day.

Range Switches



AMPTEC 620VL Range Switches shown

The AMPTEC 620VL ohms ranges are manually selected by pressing the desired range switch on the front panel. The range select pushbutton for the lowest resistance range 20 Ohms (leftmost resistance range button) indicated above the range select buttons. When a given range is selected (pushed in) the other range switches "pop-out" and inform the user. It is obvious to the 620 user which resistance range has been selected, as it is pushed in. Also

Note that a resistance range should be selected after powering up the 620VL



In order to place it in an operational mode. After turn "ON", a range should be selected. If the resistance being measured (including "Open Circuit/ Disconnected states") is a higher value than the selected range, the instrument's display will flash (blink) , which indicates "overrange" . The front panel "remote" switch **must be pressed** to place the AMPTEC 620VL Igniter Tester out of any manually selected range(s) for automated control via the RS232C Interface.

Gold Plated Five way Input Jacks

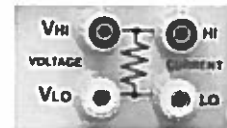

The AMPTEC 620 front panel input jacks are a gold plated variety that readily accept a number of user connection modalities. The unit's banana post input jacks may be unscrewed several turns to exposed a horizontal hole thru the gold plated post. The AMPTEC 620 user can directly connect a bare wire thru the banana post (horizontal hole). Once the wire is thru the banana post hole you can hand tighten the banana post to make a secure electrical connection. The AMPTEC 620 front panel input posts also accept wires with spade lugs, and or banana jacks. The 48" long dual banana Alligator Test Leads plug directly into the Voltage High and Voltage low , and Current high and Current low panel jacks. The spacing of the AMPTEC 620 panel jacks only allows horizontal connection of the dual banana jack test leads to prevent mis-connection.

Calibration Access Screws

Recessed in the feet on the bottom of the AMPTEC 620VL you will note there are 4 screws (phillips type) used for calibration access. They are meant to remain intact and to be removed by authorized Calibration Lab staff.

Sect. D - Operation, Functional Self-Test and Use

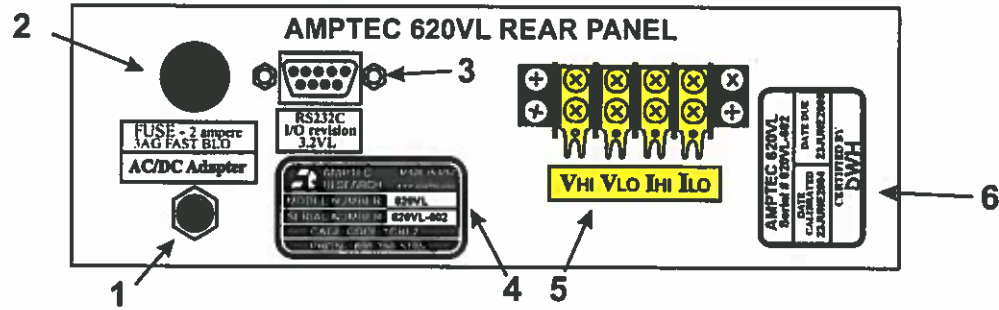

AMPTEC 620VL Rear Panel

The AMPTEC 620VL rear panel (shown above) contains many jacks, terminals, labels, and stickers.

The AC to DC Adapter (item #1) must be left in the rear panel jack in order to continuously operate the unit.

Item 2 is the fuse holder - replace with a 2 ampere 3 AG type fast blow fuse (rarely needs replacing).

RS232C Serial Interface - Item # 3 is the safety isolated RS232C serial interface (9 pin D type Sub-min connector). This RS232C Interface provides the meter's resistance measurements to a PLC fitted with a serial port. The RS232C protocol settings should be **9600 Baud, 8 Bits, No parity, 1 Stop Bit, 9 pin D Sub-min connection.**

RS232C Command Set

Important note : *Deselect any manually selected range (press any range button half-way) in order to use any and all RS232C control and commands. Note commands are case sensitive (send all CAPITAL CASE keys only from you PC keyboard) .*

C Continuous Read Mode - RS232C I/O outputs a data string every A to D conversion cycle, approx. 2.5 times per second.

S Single Read Mode - RS232C I/O outputs a single data string upon reception of a "R" command.

R Read - Commands RS232C I/O to output a single data string (1 resistance reading).

- r0 Selects local mode
- r1 Selects the Diode Test mode function
- r2 Selects the 2 KOhm Range
- r3 Selects the 20K Ohm Range
- r4 Selects the 200K Ohm Range
- r5 Selects the 2 MegOhm Range
- V Version commands board to output the firmware version string.

Data Format - The RS232C I/O outputs a data string with the following format:

1.2345E+3 means the measurement (in Ohms) is in scientific notation = 1.2345 KOhms (where E⁺³ = 10⁺³). 9.999Ex is "over-range" possibly open circuit (where x depends upon the selected range). If the format returned is 1.2345E+0 then the unit is in Diode Test Mode. The Exponent is defined below.

Range	Exponent	Notes
20.0 Ohm	E+1	An overrange condition is indicated by 9.9999Ex
200.0 Ohm	E+2	
2.0 K Ohm	E+3	Where x is the selected resistance range exponent.
20 K Ohm	E+4	
200 K Ohm	E+5	A range error is indicated by x.xxxxERR.
2.0 M Ohm	E+6	

If the reading format returned is 1.2345E+0 then the unit is in Diode Test Mode.

Item # 4 is the unit's serial number sticker.

Item # 5 is the gold plated 4 terminal Kelvin rear terminal strip, wired in parallel with the front terminals). For a "2 wire ohms" connection the V high and I high terminals should be shorted together, and the V low and I low terminals should be shorted. The 620VL Voltage High, Voltage low, Current Ihigh and Current Ilow wires are wired to the gold plated rear terminal strip (see terminal strip diagram above).

Item #6 Calibration Sticker - Calibration interval is 1 year from previous calibration. AMPTEC customer service 1-800-350-5105 can re-certify the 620VL Explosive Safety Igniter Tester calibration.

Sect. D - Operation, Functional Self-Test and Use

In many resistance measurement applications the contact resistance can exceed the value of the test resistance by several orders of magnitude. The AMPTEC 620VL overcomes this potential error source by providing two terminals of constant current (I high and I low) and an additional two terminals for high impedance voltage measurement. The constant current source uses a variable compliance voltage circuit to overcome lead and contact resistance until the current loop is a constant level. The result is a fast, accurate resistance measurement of the test resistance, independent of the resistance of the current carrying leads.

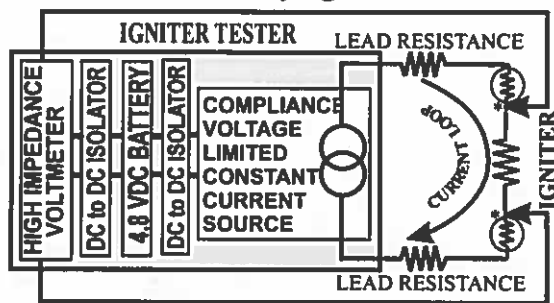

* contact resistance
Figure D-1 - Igniter Tester Kelvin Block Diagram

Figure D-1 above illustrates the 4-wire principle eliminates lead, wire and contact resistances as potential error sources. The internal constant current source inherently overcomes all series resistance (within compliance voltage limits) and delivers a precise constant current. *Separate DC to DC isolation circuitry provides independent circuit voltage supplies for both polarities of the constant current source circuit.* The internal high-impedance Digital Voltmeter (DVM) senses the voltage drop across the test resistance (i.e. squib or detonator). There is negligible contact and lead resistance error created by the voltage measurement because the high input impedance of the DVM limits current flow in the voltage (V_{hi} and V_{lo}) leads.

D-4. Connections

Connections should be made to the front and rear panel terminals using a 4-wire configuration as described in section D-3. Next connect the 4 wire Kelvin (Option "300") Clip Test Leads into the AMPTEC 620 Igniter Tester. The AMPTEC 620 front panel input jacks are spaced to only allow horizontal access (i.e. V_{high} and I_{high}) if using dual banana

Jacks. All AMPTEC 620VL Kelvin leads have the 4 wire current high, current low as well as the voltage sense high and voltage sense low routed to the end of the leads. The 4 wire Kelvin wires then terminate in a pair of gold plated clip jaws (upper and lower jaws). One Kelvin Clip for current and voltage high, and another Kelvin Clip for current and voltage low.

For 620 series test leads other than those terminated with banana plugs, RG-58 Shielded Coax Cabling is recommended. Customer built test wiring should maintaining the four wire Kelvin measurement if possible. Make the current conductor the largest conductor and keep the voltage sense input shielded or inside the current shield. The AMPTEC 620 series Igniter Tester's five way input jacks allow for customized wire connections, extended kelvin wiring (beyond 100 feet depending upon conductor gauge), cables terminated with spade lugs, and special banana jacks can all be used with the AMPTEC 620 Tester.

All AMPTEC ohmmeters use a high impedance voltmeter as part of the resistance measurement process. This voltmeter is a highly accurate and stable $4\frac{1}{2}$ digit analog-to-digital converter (A to D). The high impedance DVM must receive a voltage drop in order to display the proper value. When the DVM is not receiving a definite input signal, the output reading from the Analog to Digital Converter can appear random and wandering. The display may indicate a randomly wandering number or it may indicate an overrange (flashing) condition. This unpredictable display (No input to the DVM) condition is not a malfunction, in fact, just a characteristic of the high impedance voltmeter circuit and *should not be mistaken for a fault in the instrument* - As this condition is simply a state of an "open circuit" or "nothing connected" to the DVM circuitry. A flashing display (on and off usually all zeros) indicates an over-range condition whenever the test lead terminals are open, or the resistance under test is a higher value than the range selected on the AMPTEC 620 tester. *Connecting V_{HI} to I_{HI} and V_{LO} to I_{LO} eliminates the wandering (open circuit) display condition.*

Sect. D - Operation, Functional Self-Test and Use

By using a 4-wire Kelvin type lead set or by shorting the V_{hi} and I_{hi} terminals together and V_{low} and I_{low} terminals together the instrument is in the 2 wire resistance mode.

Resistance Offset in 2 Wire mode

All wiring including harness wires from the two wire test connection out, that are "in series" with the test squib resistance become part of the actual two wire measurement (*another potential source of measurement error if not compensated for*). Many Ordinance test procedures have the 620 series Igniter Tester user short their wiring harnesses at the very end (by the squib) and record the resistance value or offset. Then when the 620 series Igniter Tester leads, including the in-series harness wiring resistance, is connected to the test squib, the squib test resistance can be calculated (via subtraction of the 2 wire harness - test lead resistance offset).

That is the 2 wire lead length shorted offset resistance (without the squib resistance) can be subtracted for the total resistance (including the squib resistance) to determine the actual squib (test) resistance.

Identifying a Test Connection problem

A precision 1.0 Ohm test resistor is also located in the optional Functional Test Box (FTB-620VL) available from AMPTEC. The 1.0 Ohm test resistor can be used for testing mid-scale performance of the 2.0 Ohm range. Performing a similar Functional Test with the 620VL meter across the 1.0 Ohm test resistor should get a reading close to 1.00 Ohm (i.e. 0.9995 Ohms is OK). If the 620 Series Igniter Tester appears OK after checking the test resistors in the Functional Test Section then the connection problem must be outside of the 620 series meter (i.e. your wiring harness or the actual device under test connection.) If the 620 series meter doesn't agree with the test resistors in the Functional Test Box, then the meter or its test leads are most likely broken. If this case, please contact your local AMPTEC RESEARCH Service Office, or call 1-800-350-5105 or (512) 301-9333 (International Overseas) or FAX (512) 301-9303, email service@amptec.com

The AMPTEC 620 display should indicate a stable reading when the test leads are securely attached to the device under test. If the display appears to be erroneous when connected to the resistance under test, recheck the test leads for integrity and cleanliness. If all external items appear to be functioning properly, the next step in problem isolation and diagnosis involves general trouble-shooting principles. If a measurement problem appears on the 2.0 Ohm range of the meter, test for a zero offset problem first. Plug the 620 with Kelvin test leads into a 0.10 test resistor (i.e. AMPTEC # FTB-620VL). If the meter doesn't display a value close to 0.1 Ohms adjust the zero (see calibration procedure chapter). The zero adjustment trimpot only has enough span to zero out the 620 series test leads. The meter's zero adjustment pot wasn't designed to zero out a 100 feet of 2 wire harness.

D-5. Failsafe Operation

The AMPTEC 620 Series of Igniter Testers or failsafe ohmmeters incorporate a constant current source design that renders them incapable of delivering excessive voltage or current to the device under test. The typical fail-safe current for each range is indicated with most AMPTEC models under the corresponding range switch on the 620 series meter front panel. Please refer to section E-6 for a technical description of the failsafe circuitry specifics.

As a precaution the 620 Series Igniter Tester is isolated (3KV) from the AC/DC Charger whenever the POWER switch is in the ON position (3KV) or "OFF". The unit's "main power switch" does not have to be switched "OFF" to charge the batteries.

Constant Current Circuit Operation

Assume that terminals I_{hi} and I_{lo} of Figure E-3 are shorted, and 0.5 volt is applied to E_{in} so that I_{hi} is positive. To equalize the 0.5 volt applied to E_{in} , the inputs of IC202, IC201 must be driven to zero. This condition occurs only when the voltage drops across R212 and R222 are equal to the drops across R213 and R221. For these voltage drops to be equal, the output of IC202 must be at +1.0 volt. Since the output of

Sect. D - Operation, Functional Self-Test and Use

IC201 must be zero, the drop across R213 is 0.5 volts, making the inverting input 0.5 volts. The drops across R212, R221 and R222 will also be 0.5 volts. Since the inputs to IC201 are essentially equal, its output is zero (offset by the few microvolts required to drive IC202 to +1.0 volt). Under these conditions the sum of the voltages across R212, R213, R221 and R222 equals the sum of E_{in} plus the output of IC202.

Consider now that the short is removed from the I_{hi} and I_{lo} terminals and a 100-ohm resistor (R_L) is connected in its place. The current through R_L increases the voltage at the input to IC201. A balanced condition will be reached when the output of IC201 is equal to the non-inverting input of IC202. Again, this condition occurs when the voltage drops across R212 and R222 are equal to the voltage drops across R213 and R221. At this time the output of IC202 is 1.0 V. The voltage drop across the range resistor is 1.0 V, just as it was when the output terminals were shorted. The current through R_L is 10 mA, just as it was through the jumper when the output terminals were shorted.

The 620VL Explosive Safety Igniter Tester measurement circuitry is failsafe current limited, even under worst case component failure.

For the 620VL Explosive Safety Tester the normal or typical operating current level is less than equal to ~ 5 mA, and <8 mA on 20 Ohm range as a Failsafe Level .

Reference to the AMPTEC 620VL Igniter Tester schematic will show that the output of IC202-6 is actually applied to the base of transistor Q202, which acts as a current limiter. The worst-case component failure that could occur in this circuit would be a Q202 short, which would effectively connect the -5 volt supply directly across R218, D202, the range resistor and R_L .

D203, however, acts as a 1.6 volt zener diode, limiting the voltage that can appear across the current output terminals. Even if every component in the amplifier circuit shorted, the current through the igniter could not exceed safe limits, because the -5 volt and +5V supplies includes inherent current limiting. Because of the design of both supply isolation transformers T101 and T102, the ± 5 volt supplies can only deliver 20 to 25 milliamperes before the DC/DC converter disengages, dropping the -5 volt output to zero.

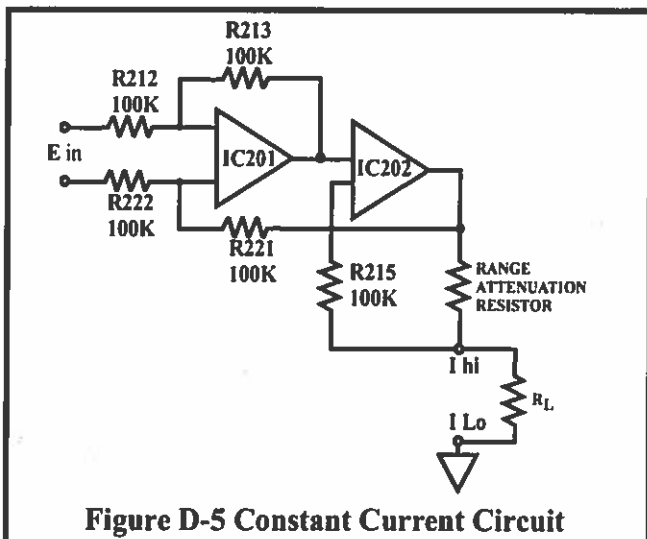

CHAPTER E - GENERAL OPERATION AND DESIGN

E-1. General

The AMPTEC RESEARCH 620VL Explosive Safety Igniter Tester is shown in the block diagram (Figure E-1). All diagrams and information disclosed in this chapter is proprietary and is included in order to make troubleshooting to component level possible.

The AMPTEC 620 Series Igniter Tester uses modern solid-state semiconductors exclusively and digital CMOS circuits extensively to minimize power requirements and make battery operation useful and practical. AMPTEC also maintains a spare parts inventory of all components found in the 620VL Tester and its customer service department can also provide additional assistance in the trouble shooting process.

E-2. Troubleshooting

Since the 620VL Tester is used to test potential deadly explosive force detonators and warheads of missiles etc., *personnel that are not qualified to make such electrical repairs on the 620VL Tester should not even attempt to remove the calibration access screws or open the main panel or effect any repair whatsoever.*

Apparent 620VL Tester malfunctions can sometimes be the result of bad test lead/connection wiring, wrong connections, misinterpretation of specifications, low battery levels, and in rare cases due to an incomplete understanding of the instrument and how to use it. A thorough review of the operating instructions for this instrument is recommended prior to any component replacement. Check to be sure that cables and other test equipment are in good working order before attempting to troubleshoot the 620VL series igniter tester .

If you turn on the AMPTEC 620VL Explosive Safety Igniter Tester and the display does not come on it usually means the AC to DC Adapter isn't supplying power or fuse needs replacing.

If the 620VL exhibits problems that cannot be eliminated by reviewing Chapters B and D, the following guidelines have been established to help solve the problem.



E-2-1. Localizing the Problem

Chapter D-2 discusses how to use the *Functional Test Box (FTB-620VL)* with the 620VL Tester to help localize the problem. The key to successful troubleshooting is to localize the problem to a general electronic parameter as much as possible before trying to pin the problem down to a specific component. Certain questions should be asked such as "Does the problem occur on all ranges or on a specific range only?". If the 620VL Tester does not come on when powered up, did you check the rear panel fuse. The power supplies for both the current source and the digital voltmeter electronics are also one of the first things that should be tested. As it is not possible to anticipate all failure modes of the 620VL Explosive Safety Igniter Tester, servicing personnel should become familiar with this section to gain a complete understanding of the internal workings of the ohmmeter.

E-2-2. Component Replacement

If the malfunction is a faulty component, the accuracy of the 620 Series Igniter Tester can be maintained only if it is re-calibrated after a component replacement and the following precautions are taken:

Use only the specified component or its exact equivalent. Spare parts can be ordered from your nearest AMPTEC RESEARCH Service Center or directly from the factory by referring to the AMPTEC Stock Number listed in the Parts Lists section at the back of this manual.

The highest quality 63/37 grade rosin core electronic grade solder with a 50W or lower maximum power soldering iron should be used. Never use an acid core solder as corrosion of components leads and PCB etch loss can occur.

Sect. E - General Operation and Design

When soldering, heat the PCB pad and the lead of the component, not the solder. After several seconds of the component lead in contact with the hot soldering iron apply solder smoothly and evenly onto the PCB pad and component lead not the soldering iron. Do not touch or move the replacement part until the solder has cooled. Cold solder and bad solder joints can cause more problems.

Use the chassis ground (connect to the common terminal of the functional test section) connection - i.e. connect to an earth ground to avoid a static discharge to a static sensitive component. Handle all 620VL internal components as if they are static sensitive if you are not sure.

See Next Page for Start of 620 Circuit Descriptions and Functional Diagrams

E-3. Circuit Descriptions

The circuit descriptions which follow are referenced to Figures E-1, E-2, E-3 and the schematic diagrams at the back of this manual. In the following descriptions, references to integrated circuits are given in the form "IC201-1", which refers to Integrated Circuit 201, pin 1.

E-4. Analog to Digital Conversion

The A to D conversion is done with a ICL8068 /ICL71C03 chip set. The ICL8068 takes care of the analog part and the ICL71C03 takes care of the digital part of the 4 1/2 digit 20,000 count dual slope conversion.

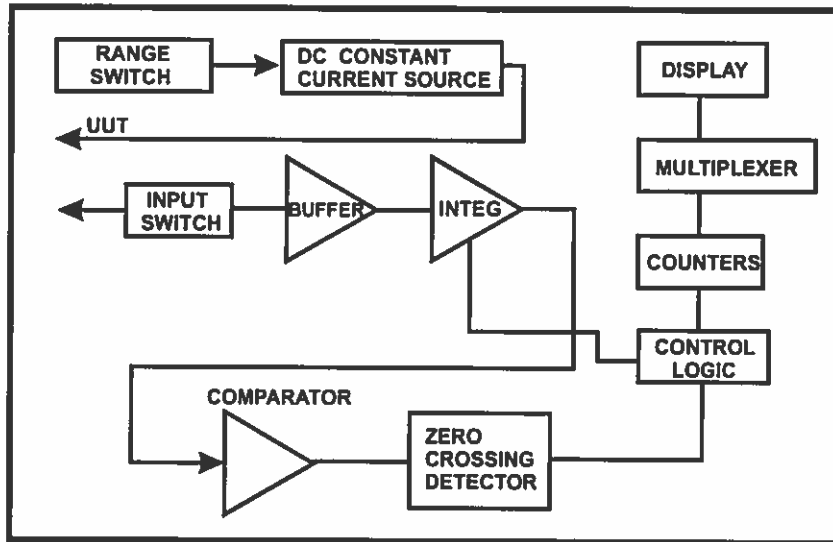

Figure E1 - AMPTEC 620VL FUNCTIONAL BLOCK DIAGRAM

COUNTS			
	PHASE I	PHASE II	PHASE III
4 1/2 DIGIT	10.001	10.000	20.001

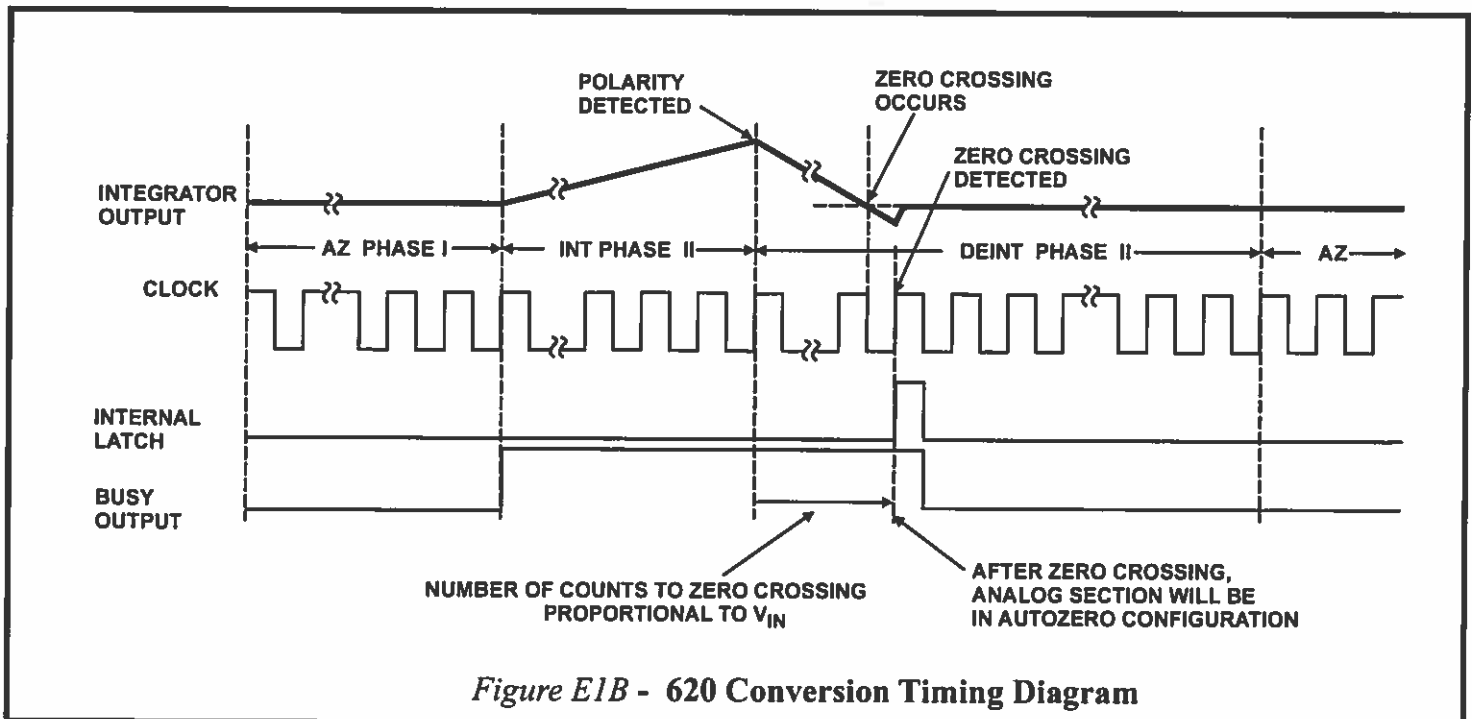
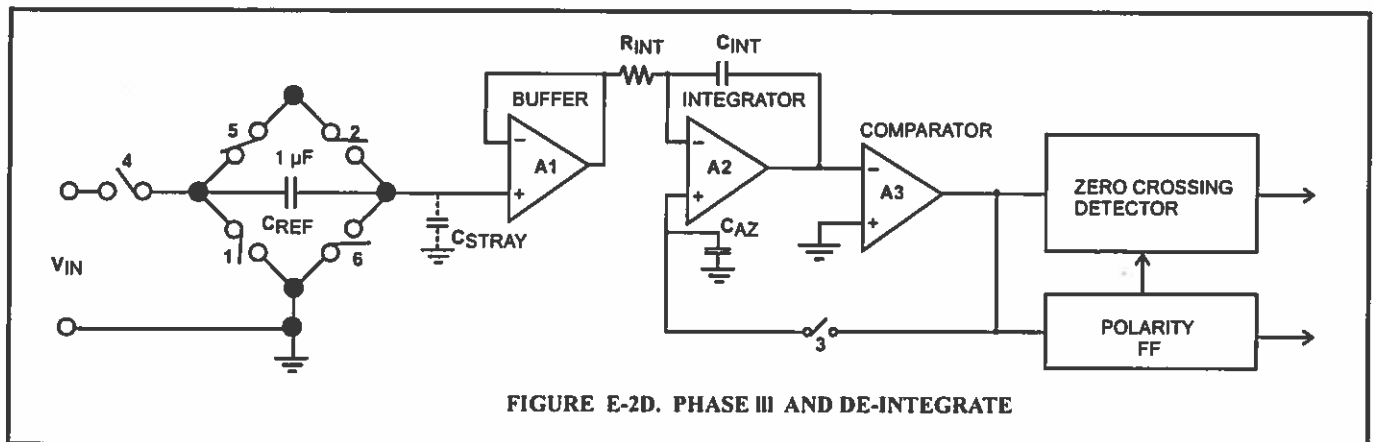
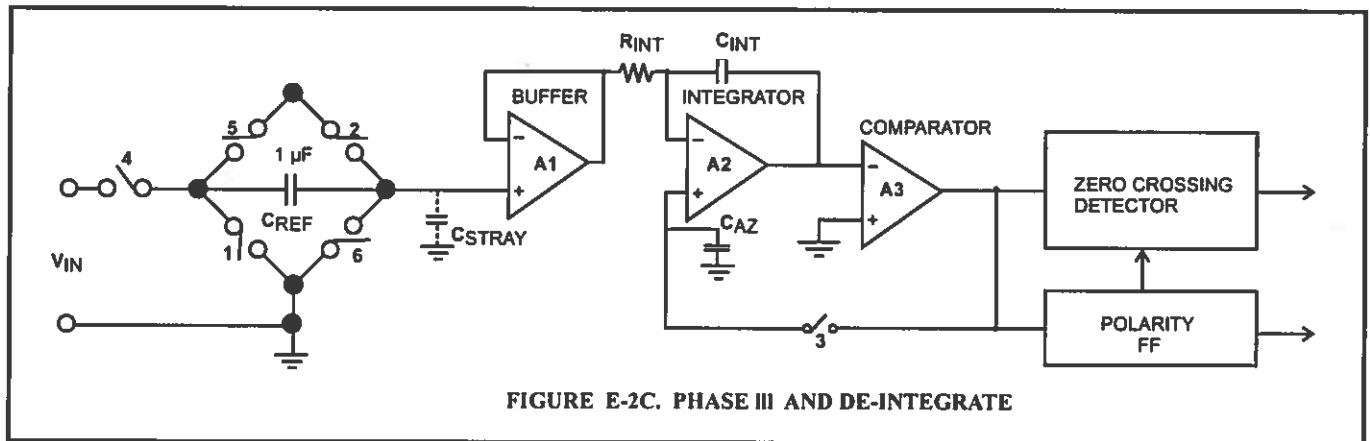
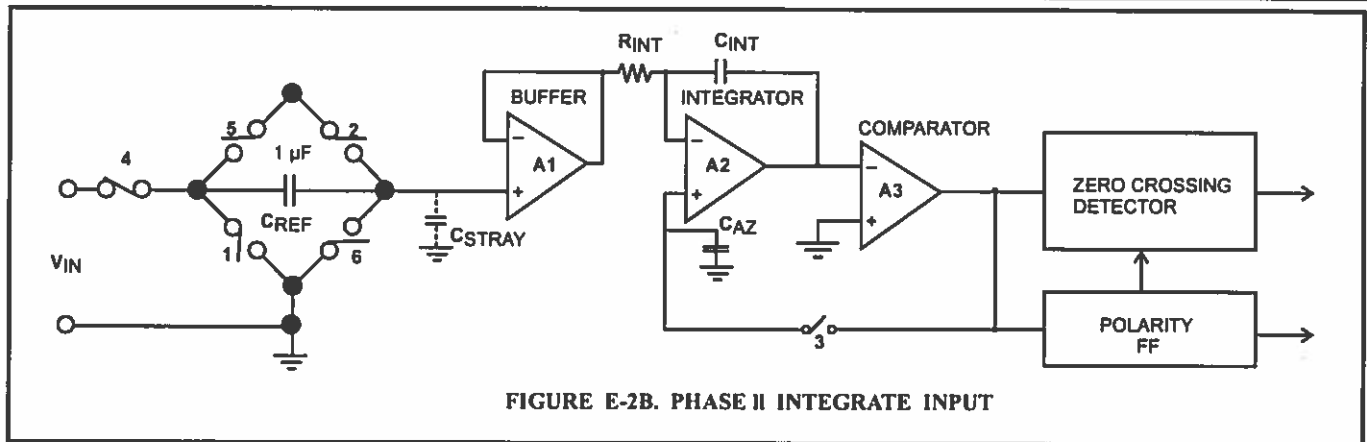
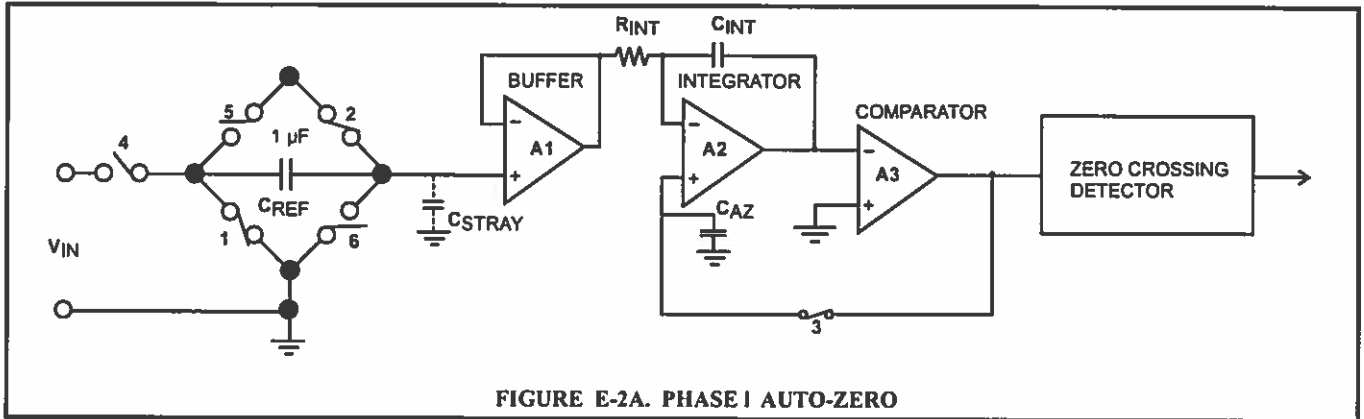

Figure E1B - 620 Conversion Timing Diagram

Sect. E - General Operation and Design



Figures E2. Main Analog Section of DVM Circuit - IC1 and IC2

Detailed Description

Analog Section

Figures E2 diagrams A thru D shows the equivalent circuit of the analog section in 3 different phases of operation. The system will perform conversions at a rate determined by the clock frequency 40,002 clock periods per cycle. (see Figure E1B shown earlier in this chapter for details of conversion timing).

Auto-Zero Phase I (Figure E2A)

During the Auto-Zero, the input of the buffer is connected to V_{REF} through switch 2, and switch 3 closes a loop around the integrator and comparator, the purpose of which is to charge the Auto-Zero capacitor until the integrator output does not change with time. Also, switches 1 and 2 recharge the reference capacitor to V_{REF} .

Input Integrate Phase II (Figure E2B)

During Input Integrate the Auto-Zero loop is opened and the Analog Input is connected to the Buffer Input through switch 4 and C_{REF} if the input signal is zero, the buffer, integrator and comparator will see the same voltage that existed in the previous state (Auto-Zero). Thus, the integrator output will not change but will remain stationary during the entire input integrate cycle. If V_{IN} is not equal to zero, and an unbalanced condition exists compared to the Auto-Zero Phase, the integrator will generate a ramp whose slope is proportional to V_{IN} .

Deintegrate Phase II (Figures E2C and Figures E2D)

During the Deintegrate phase, switch 5 is closed and a voltage which is V_{REF} more positive than during Auto-Zero is impressed on the BUFFER INPUT. Thus the reference capacitor stores the equivalent voltage. This returns the output of the integrator to the zero crossing point established in Phase I. The time, or number of counts, required to do this is proportional to the input voltage.

E-4-1. Reference Voltage

The precision reference voltage required to do the A/D conversion is developed by IC201. The zener voltage is attenuated to approximately -0.5V. This voltage is applied to IC2-7.

E-4-2. LED Display

The output format from IC2 is in Binary Coded Decimal (BCD) format. Each digit is scanned for 10 clock pulses. The scan sequence is D5 D4 D3 D2 D1. This drives Q1 thru Q5, which in turn drives the seven segment displays. The BCD data is converted to seven segment format by IC4. When the 620VL electronics are in open circuit or over-range mode the display flashes "0000". IC5 is a 1 MHz oscillator which is divided by 10 by IC6. The 100 KHz clock output then goes to IC2.

E-5. Ohms-To-DC Converter

The ohms-to-DC converter generates a constant current which is passed through the device under test to develop the voltage measured by the A/D converter.

E-5-1. Constant Current Source

The constant current source is composed of IC201, IC202, Q202, D203 and their associated components. The input to the constant current source is approximately +1.05 volts, developed at IC201-7 and connected to IC201-13 through R209 and R210. The heart of the constant current source is the voltage-to-current converter. A simplified schematic of this circuit is shown in Figure E-4 and described in Section E-5-2. The amplifier of IC201-12 is an inverter, and its output is applied to IC201-9. The amplifier of IC201-8 has unity gain due to the feedback through R213. Its output is applied to the inverting input of IC202-3. The output of IC202-6 provides feedback to the non-inverting input of IC201-10. This circuit operates to maintain the inverting input at IC202-3 and the non-inverting input at IC202-2 at the same potential.

Sect. E - General Operation and Design

E-5-2 Constant Current Circuit Operation

Assume that terminals I_{hi} and I_{lo} of Figure E-3 are shorted, and 0.5 volt is applied to E_{in} , so that I_{hi} is positive. To equalize the 0.5 volt applied to E_{in} , the inputs of IC202, IC201 must be driven to zero. This condition occurs only when the voltage drops across R212 and R222 are equal to the drops across R213 and R221. For these voltage drops to be equal, the output of IC202 must be at +0.5 volt. Since the output of IC201-8 must be zero, the drop across R213 is 0.25 volts, making the inverting input 0.25 volts. The drops across R212, R221 and R222 will also be 0.25 volts. Since the inputs to IC201 are essentially equal, its output is zero (offset by the few microvolts required to drive IC202 to +0.5 volt). Under these conditions the sum of the voltages across R212, R213, R221 and R222 equals the sum of E_{in} plus the output of IC202.

Consider now that the short is removed from the I_{hi} and I_{lo} terminals and a 100-ohm resistor (R_L) is connected in its place. The current through R_L increases the voltage at the input to IC201. A balanced condition will be reached when the output of IC201 is equal to the non-inverting input of IC202. Again, this condition occurs when the voltage drops across R212 and R222 are equal to the voltage drops across R213 and R221. At this time the output of IC202 is 0.5 volts. The voltage drop across the range resistor is 0.5 volt, just as it was when the output terminals were shorted. The current through R_L is 5 milliamperes, just as it was through the jumper when the output terminals were shorted.

E-6. Failsafe Design

Reference to the AMPTEC 620VLTester Igniter Tester schematic will show that the output of IC202-6 is actually applied to the base of transistor Q202, which acts as a current limiter. *The worst-case component failure that could occur in this circuit would be a Q202 short, which would effectively connect the -5 volt supply directly across R218, D202, the range resistor and R_L .*

D203, however, acts as a 1.6 volt zener diode, limiting the voltage that can appear across these components. Even if every component in the amplifier circuit shorted, the current through the

Igniter could not exceed safe limits, because the -5 volt and +5V supplies includes inherent current limiting. Because of the design of both supply isolation transformers T101 and T102, the ± 5 volt supplies can only deliver 20 to 25 milliamperes before the DC/DC converter disengages, dropping the -5 volt output to zero. See Section D.

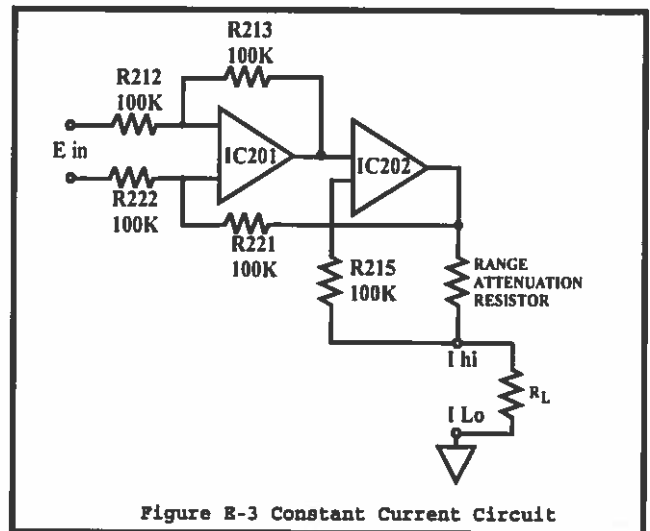

Figure E-3 Constant Current Circuit

620VL Failsafe Current Calculation - Worst case Component Failure

Voltage limiting diode, D203, provides a 1.6 volts maximum across R227 (100 Ω) and R223 (100 Ω), which are 200 Ohms across the Igniter Testers output terminals.

(I_{max}) Current Maximum Calculation

$$1.6V/200 \text{ ohms} = 0.008 \text{ Amperes} \\ (8\text{mA}) \text{ max}$$

Sect. E - General Operation and Design

The 620VL Tester measurement circuitry is also failsafe current limited, even under worst case component failure. A simple startup test procedure which also has the 620VL Tester user perform a functional check using the optional "FTB-620VL" Functional test box with milliammeter would also detect any current level even getting close to the Failsafe level.

For the 620VL Tester the normal or typical operating current level is less than 5 mA, and <8mA on as a Failsafe Level .

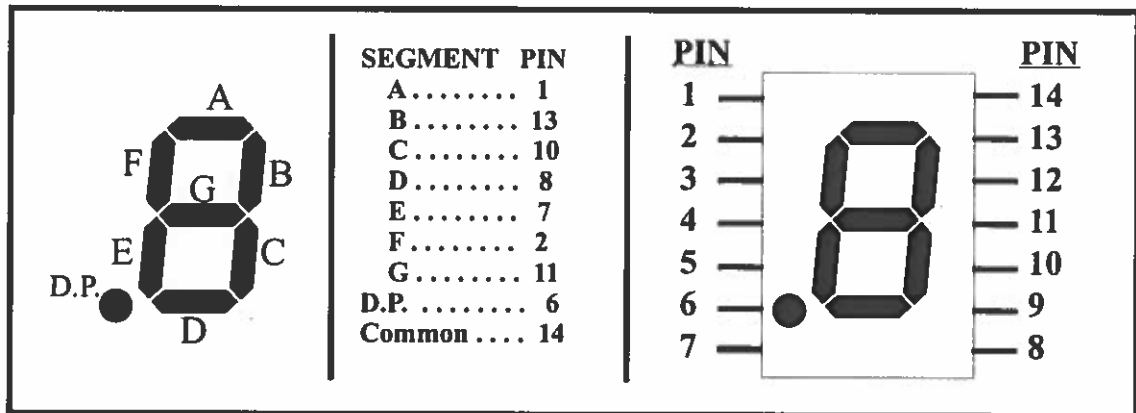
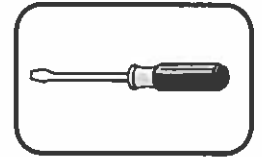

Figure E4 - 620 series LED Display Pin Out Detail/Functions



CHAPTER F - CALIBRATION AND MAINTENANCE



F-1. General

This section of the manual contains routine maintenance information regarding the AMPTEC RESEARCH Model 620 series Igniter Tester. Calibration should be performed on a regular basis to ensure continued instrument accuracy or following a main PCB electronic component repair/replacement. The recommended calibration interval is 1 year.

All AMPTEC 620 series Igniter Testers are four wire Kelvin compensation ohmmeters. *The 620VL Igniter Tester must be calibrated using four wire Kelvin connections to the resistance standard* in order to eliminate lead resistance and contact resistance errors. The Option "290" has 48" long coax test cabling terminated with twin single alligator clip jacks will not work properly for calibrating the 620VL.

Note: Only for 620 versions with a 2 Ohm range: Option "300" is a 48" long Gold Plated Kelvin Clip Lead set optionally supplied as part of the AMPTEC 620 accessories is recommended for the actual calibration of 620 Igniter Testers versions fitted with a low 2.0 Ohm range.

F-2. Required Test Equipment

Following standard resistors are required to calibrate the 620VL Igniter Tester .

Precision Resistors:

- 1 ohm \pm 0.01% or better accuracy
- 1.0 Kohm \pm 0.005% or better accuracy
- 10.0 Kohm \pm 0.005% or better accuracy
- 100 Kohm \pm 0.005% or better accuracy
- 1.0 Mohm \pm 0.1% or better accuracy

Test Leads:

AMPTEC "Option 300" Kelvin Clip Lead Set

F-3. Calibration Procedure

The 620VL Igniter Tester should be calibrated with fully charged batteries and should be allowed to **warm-up** for a minimum of **15 minutes** before beginning the procedure. The calibration adjustments are accessed by removing the screws in the feet on the bottom of the unit, then lifting off the lid. The locations of the adjustments are shown on drawing number 620VL-600 at the back of this manual.

F-3-1. Zero Offset Adjustment

1. Select the 2.0 K ohm range. Connect the Kelvin clips to the 1.0 ohm standard resistor.
2. Adjust potentiometer RV2 for a display indication of 00.10 KOhms . *Do not over adjust RV2 past a 0.00 reading.* A false or negative polarity 0.010 display reading offset error can be created. This calibration error has the display appearing normal (even though a negative 0.0010 offset has been created) - the display doesn't indicate a negative sign).

F-3-2. Full Scale Adjustment

1. Select the 2 Kohm range. Connect the Kelvin clips to the 1.0 Kohm standard resistor.
2. Adjust RV1 for a display reading of 1.0000 Kohms.
3. Check the 2.0 MOhm range with the 1.0 MOhm Standard Resistor. Check the 200 KOhm range with 100 KOhm Standard Resistor. Check the 20 KOhm range with 10 KOhm Standard Resistor. All ranges must be within the specifications outlined in Chapter B. *There are no adjustments necessary for the 2.0 MegOhm and 200 KOhm ranges.* Contact AMPTEC's customer service department if further technical support is necessary.

F-4. AMPTEC 620VL DIODE TEST

The diode test function of the 620VL Tester is for checking diodes. To do this, the voltage compliance output of the constant current supply is increased and the voltage sensitivity of the voltmeter section is decreased. When a **1N4001 diode** is connected, the AMPTEC 620VL Tester will read the voltage across it. The diode will have approximately 0.6 volts across it. This equals a reading of about $.2400 \pm .03$. A 14K Ohm resistor will have a reading of approx. 1.9800 on the display. If a 14 Kohm resistor is tested with the diode test function, it will indicate a reading of 1.9800 ± 100 counts on the 620VL display.

Adjust RV4 to read 1.9800 ± 100 counts on the 620VL display using a 14 K Ohm 0.1% resistor as a standard. Then check it against a **1N4001 diode**, it should read $.2400 \pm .03$.

