



**MODEL 630ES
WATER-RESISTANT IGNITER TESTER
OPERATION/MAINTENANCE MANUAL**

Rev. E, May 2023

Amptec Research Corp.
13231 Rooster Springs Rd.,
Austin, TX 78737 USA
+1 (512) 858-4045 // info@amptec.com
www.amptec.com

A MESSAGE FROM THE FOUNDER

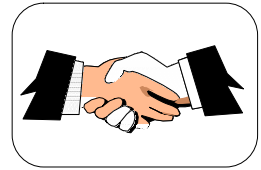

We at AMPTEC RESEARCH would like to thank you, our customer, for selecting our Failsafe Igniter Tester/ Digital Ohmmeter. Over the past 36 years our experienced engineering staff have designed, manufactured and supplied earlier versions similar to the Model 630 Series Igniter Testers to the U.S. NAVY for the “*CRUISE MISSILE*”, the U.S. ARMY for the “*STANDARD MISSILE*”, the U.S.A. F. for the AIM-9 “*SIDEWINDER*”, AIM-7 “*SPARROW*” and AIM-120 “*AMRAAM*” just to name just a few. We value the trust our customers have placed with us, and are looking forward to supporting any new requirement you may have

Kerry Clark, Founder AMPTEC RESEARCH

U.S. N.I.ST. CALIBRATION CERTIFICATE



AMPTEC RESEARCH, Inc. certifies that this instrument was thoroughly tested and inspected and found to meet published specifications as found in this manual when shipped from the factory. AMPTEC RESEARCH, Corporation further certifies that its calibration measurements are traceable to the U.S. National Institute of Standards and Technology.

630 SERIES (630xx) IGNITER TESTER WARRANTY

Permission and a return authorization (**RMA**) number must be obtained directly from AMPTEC’s customer service department (via phone, FAX, or email) for repairs (warranty or otherwise). We need to issue you an RMA number so we can keep track of the instrument and it’s owner (i.e. who to contact). The warranty period for this instrument is 1 year from when it was first shipped. AMPTEC RESEARCH will repair or replace the instrument during the warranty period provided it is returned to AMPTEC RESEARCH, freight prepaid. No other warranty is expressed or implied. We are not liable for consequential damages. No liability will be accepted if returned without such permission.



Some AMPTEC products may have their design frozen, and no changes will be made without prior notice to the proper approving authority. Through out this manual, there is reference made using to the generic model 630 series Igniter Testers. There are many versions of the 630 Igniter Tester specifically developed to meet our customers requirements. The specification, operation, drawing and schematic sections of this manual contain the unique detail that define the 630XX. Due to continuing product refinement, due to possible parts going obsolete and other component manufacturer changes, AMPTEC RESEARCH reserves the right on rare occasions to change any of its products specifications.

TABLE OF CONTENTS

SECTION A: UNPACKING AND INSPECTION

- A-1 Introduction to the AMPTEC 630ES
- A-2 Unpacking and Inspection
- A-3 Opening the 630ES Ohmmeter and Removal of the Lid
- A-4 AC Adaptor/ Battery Charger- Power Requirements
- A-5 Setup and Use



SECTION B: 630ES Explosive Safety Igniter Tester SPECIFICATIONS

Table B-2. Specifications

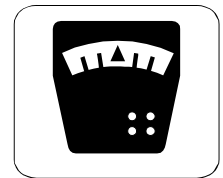

SECTION C: REPLACEMENT, OPTIONAL AND ACCESSORY ITEMS

- C-1 Available Accessories and Options
- C-2 Test Lead Sets



SECTION D: OPERATION AND USE

- D-1 General
 - D-2 Front Panel Features and Operation
 - D-3 Fuse Holder
 - D-4 4-Wire Resistance Measurement
 - D-5 Connections
 - D-6 Failsafe Operation
 - D-7 Battery Monitoring Circuitry
 - D-8 Zero Pot
- Figure D-1. Error Sources in Resistance Measurements

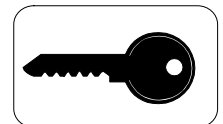

SECTION E: THEORY OF OPERATION

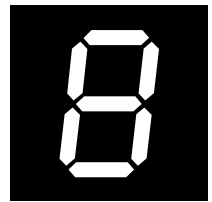

- E-1 General
- E-2 Troubleshooting
- E-3 Circuit Descriptions
- E-4 Analog-to-Digital Converter
- E-5 Ohms-to-DC Converter
- E-6 Failsafe Design
- E-7 Ultra-Safe Power Supply Scheme

- Figure E-1. Model 630ES Block Diagram
- Figure E-1B Analog-to-Digital Converter Timing Diagram
- Figure E-2 Analog Section of IC1 and IC2
- Figure E-3. Constant Current Source Diagram (Simplified)
- Figure E-4. LED Display Pin Functions

SECTION F: ROUTINE MAINTENANCE

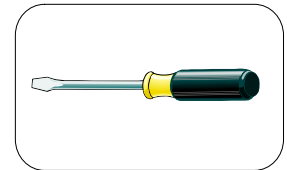

- F-1 General
- F-2 Required Test Equipment
- F-3 Calibration Procedure
- F-4 Battery Replacement Instructions

SECTION A UNPACKING AND INSPECTION



A-1. Introduction to the AMPTEC 630ES

The AMPTEC Series 620A and now the 630 Series Igniter Testers are becoming the standard in the Explosive Safety Igniter Circuit Test industry, and are designed to provide extremely safe and reliable resistance testing of explosive or volatile devices. Safety Approvals from various Safety Boards include, the U.S. Air Force (620A-4) for generic use on Non-Nuclear munitions. Some of the devices the 630ES Failsafe Ohmmeter may be used on include: fuses, squibs, igniters, explosive bolts, automobile airbag initiators and many others.

Essentially, a AMPTEC 630ES is a 4-wire failsafe digital ohmmeter which has been designed to reliably use very low test currents for its resistance measurement. Additional circuitry proprietary to AMPTEC RESEARCH is used to ensure that test current levels do not exceed the specified "failsafe current" even in a worst-case component failure situation. The failsafe feature is tested in every instrument before shipment.

The 620A and the newer 630 series represent the latest in ultra-safe Igniter Tester measurements. The 630ES uses the same main printed circuit board (PCB) as the AMPTEC 620A Igniter Tester. The 630ES has been made water-resistant and has many features which make it useful in a variety of applications. Please check the front of this manual for any addendums that may apply to new 630ESs and 630AN conversions.

A standard feature of the 630ES is a **battery monitoring** circuit that alerts the user it is time to recharge the batteries. Refer to section D-7 for more details.

A-2. Unpacking and Inspection

If the shipping carton (box) appears damaged, request that the carrier's agent (i.e. UPS) be present when the unit is unpacked. If the instrument appears damaged, the carrier's agent should authorize repairs before the unit is returned to the factory. Even if the instrument appears undamaged, it may have suffered internal damage in transit that may not be evident until the unit is operated or tested to verify conformance with its specifications. You may refer to the *Functional Test section of Section D of this manual to help identify the problem* (i.e

Test leads etc.) The 630ES has a set of test resistors built-in the Functional Test Section that can quickly help the user figure out where the problem is most of the time. If the unit fails

to operate or fails to meet the performance specifications of Section B, notify the carrier's agent and the nearest AMPTEC Sales Office. Retain the shipping carton for the carrier's inspection. **DO NOT return equipment to AMPTEC RESEARCH** or any of its sales offices *prior to obtaining* an (RMA) Return Material Authorization number.



By calling AMPTEC RESEARCH first, prior to just returning the 630ES, we can often troubleshoot (based on the symptoms you describe) and identify the problem over the phone (i.e battery loose in the battery holder). We may be able to fix the problem and prevent you from having to return the unit to AMPTEC for repair.

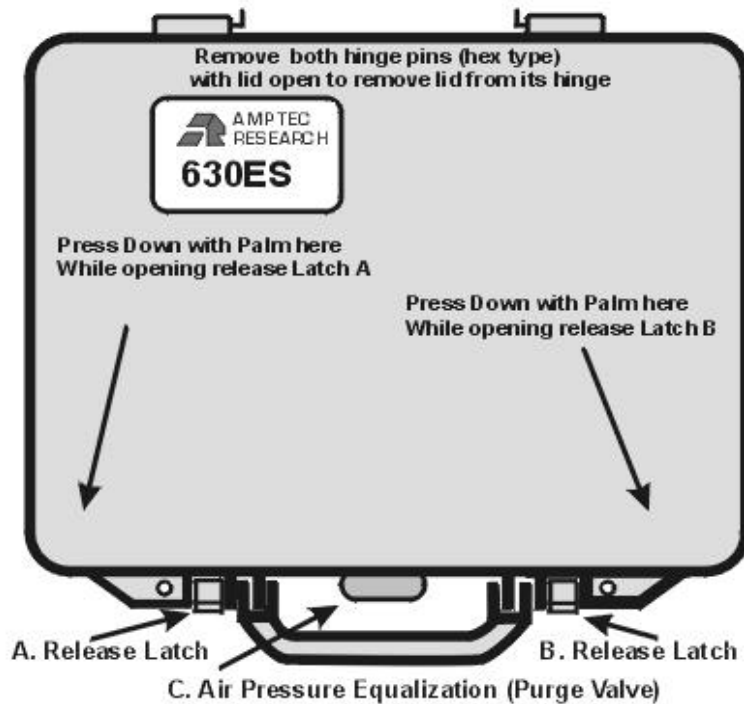

A-3. Opening the 630ES Igniter Tester and removal of the Lid

When closed, the 630ES Explosive Safety Igniter Tester has two large O-rings that provide a very water resistant and on occasion even an air tight seal. By pressing down with your palm as diagramed above you compress the O-ring in the lid of the 630ES.. This makes it easier to flip up the release latch. Repeat the palm press step on the other corner of the 630ES while flipping up the release latch. At this point the 630ES lid will normally be able to be raised, and placed in an open lid state.

If the 630ES doesn't open after flipping up the release latches, a change in atmospheric pressure since the unit was last closed may be the culprit. **Turn the Air Pressure Equalization or "Purge Valve" counter-clockwise.** Once air-pressure is equalized, the 630ES can be opened. If the Purge Valve was opened, return the valve to the closed state (tighten = clockwise) once the 630ES lid is open.

The *630ES* has a way to remove it's lid **completely**, for example when used in an indoor laboratory environment. With the 630ES open, remove the units two hinge pins (hex type) by twisting them. The lid should come free at the hinge. Once the lid is removed replace the hinge pins in the hole they were pulled out of.

A-4. AC/DC Battery Charger - Power Requirements

The AMPTEC 630ES is powered by an internal rechargeable heavy-duty nickel-cadmium battery pack (4 ea D cells).

The battery charge is maintained by an external AC/DC converter (**Option 630-DC**) that plugs into a standard 115VAC receptacle. The **Option 630-DC** Battery Charger is configured with a keyed connector that plugs into the "mating" keyed connector on the 630ES front panel.

For safety reasons, the battery charger's keyed connector blocks access to the test lead connections that are also part of the 630ES Explosive Safety Igniter Tester keyed

connector. In this way the user may not ever be able to connect any test leads while the unit is charging. The 630ES is designed so it is virtually impossible to be powered (in operating - measurement mode) directly from the AC line adapter. As an additional note, the 630ES main power switch *must also be* in the “*Off/Charging*” mode in order for the connected battery charger to recharge the 630ES’s batteries.

For customers using 220VAC 50 HZ AC line power for running the battery charger, please inform AMPTEC’s sales department at the time of your order and the appropriate adaptor will be included with the 630ES Failsafe Ohmmeter shipment for an additional fee.

A fully charged battery pack may power the 630ES for approximately 8 to 10 hours before requiring a recharge. Ampotec installs a quality set of 4 each Heavy Duty (at least 5000 mAhr available from AMPTEC) Ni-Cad batteries. The 630ES will also operate on a 4000 mAhr D cell Ni-Cads with a shortened operating time between charges.

The “Power” switch has two separate modes. The “ON” position supplies internal battery isolated power to operate the 630ES when they are charged. If you turn on the 630ES, and the display does not come on, it may indicate the batteries need charging. The “OFF/CHARGING” power switch position is for use when the batteries need charging or the 630ES is not in use. As mentioned earlier of course the AC/DC Battery Charger must be plugged into the 630ES’s keyed connector to facilitate charging the batteries.

Although the batteries are fully charged prior to shipment, it may be desirable to refresh the charge for 24 hours before use. As a rule of thumb, the 630ES requires twice as much time to fully recharge as the amount of discharge time. For example, if the instrument was used continuously for 2

hours, the AC adapter must be connected for 4 hours in order to fully restore the charge. If you need a replacement AC/DC Battery Charger for the 630A, contact the AMPTEC customer service department and request an **option “630DC”** Battery Charger.

A-5. Setup and Use

Once the AMPTEC 630ES has had it’s batteries charged for 12 to 24 hours it is ready for use. The 630ES consumes little power and generates virtually no heat. Consequently, it may be used in any area where the environment does not exceed the specifications of Table B-2.

Avoid exposing the 630ES Explosive Safety Igniter Tester to extremes of temperature which will affect accuracy and shorten battery life-span.



SECTION B - 630ES EXPLOSIVE SAFETY IGNITER TESTER - SPECIFICATIONS

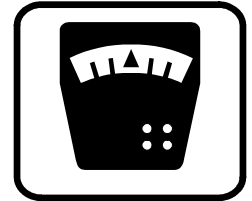

630ES Resistance Range/Resolution

| | | | |
|--------------|-------------|--------------|---------------|
| 2.0 Ω | 20 Ω | 200 Ω | 200 KΩ |
| 100 μΩ | 1.0 mΩ | 10 mΩ | 10 Ω |

630ES Nominal Test Current/Failsafe Current Levels

| | | | |
|--------------|-------------|--------------|---------------|
| 2.0 Ω | 20 Ω | 200 Ω | 200 KΩ |
| 5mA | 5 mA | 500μA | 0.5 μA |
| <8mA | <8mA | 1.5 mA | 15 μA |

Table B-2. Specifications

Accuracy: (for 1 year @25°C ± 10°C)

- 2.0 Ohm range ±0.02% of reading ±0.05% of range
- 20 Ohm through 200 Ohm ranges ±0.02% of reading ±0.02% of range
- 200 KOhm range ±0.05% of reading ±0.05% of range

Temperature Range

- Operating 0°C to 50°C
- Storage -10°C to 70°C

Temperature Coefficient

- 2.0 Ohm through 200 Ohm ranges ±0.002% per °C (from 0°C-15°C and 35°C-50°C)
- 200 KOhm ranges ±0.005% per °C (from 0°C-15°C and 35°C-50°C)

Conversion Rate Approximately 3 per second

Instrument Display .. (20,000 count) 4½ digit Super Bright Light Emitting Diodes (LED)

Over-Range Indication (select next higher range) 630ES Display flashes

Measurement Update Rate Approximately 300ms (~3 per second)

Voltage Protection - Maximum Input 250VDC or AC_{peak} without damage

Open Circuit Current Source Compliance Voltage clamped at ~1.6 volts

Power (4 "D" 5.7Ahr Heavy Duty) 1.2V rechargeable nickel-cadmium batteries

AC/DC Battery Charger (Option 630DC) provides 5.9VDC at 2.0 Ampere nominal

Dimensions 13.5" (34.3cm) W x 12" (30.5cm) D x 6"(15.2cm) H

Weight 12 lbs net; 15 lbs shipping

Functional Test Section - The 630ES Functional Test Section provides added measurement integrity using a milliammeter and test resistors to cross check the overall 630ES operation whenever desired. The test resistors are for cross checking 630ES basic operation and should not be used for calibration purposes.

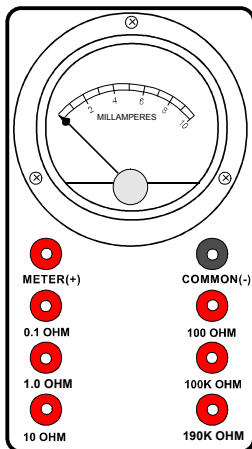

Simpson_{tm} DC Milliammeter Range - 0-10 mA fullscale, **Accuracy** ±3%

- FTSR1 **01-23572** 0.1 Ohm 1.0 % Resistor, Tc-50ppm/°C 1/4W
- FTSR2 **01-23573** 1.0 Ohm 1.0% Resistor, Tc- 50ppm/°C 1/4W
- FTSR3 **01-23574** 10.0 Ohm 1.0% Resistor, Tc- 50ppm/°C 1/4W
- FTSR4 **01-23576** 100.0 Ohm 1.0% Resistor, Tc- 50ppm/°C 1/4W
- FTSR5 **01-23580** 100 KOhm 1.0% Resistor, Tc- 50ppm/°C 1/4W
- FTSR6 **01-23582** 190 KOhm 1.0% Resistor, Tc- 50ppm/°C 1/4W



CHAPTER C - REPLACEMENT, OPTIONAL AND ACCESSORY ITEMS

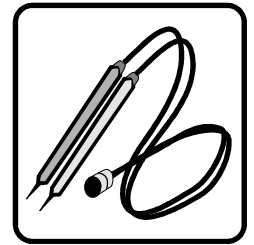

C-1. Available Accessories and Options

This manual does not list all possible accessories that AMPTEC RESEARCH is willing to provide as a support items for the 630ES Explosive Safety Meter Igniter Tester. Contact the sales department at AMPTEC if you have a request for an item that is not described here. Listed below are the options available for use with the AMPTEC 630ES Explosive Safety Meter Igniter Tester.

Option 630-BAT: Replacement Battery Pack

The rechargeable NICAD battery pack installed in the 630ES Explosive Safety Meter should provide trouble-free operation. Replacement, however, may eventually be necessary. The 630ES Explosive Safety Meter battery pack uses four "D cell" - 1.2V (5.0 AHr NICAD recommended) installed in a rechargeable battery pack.

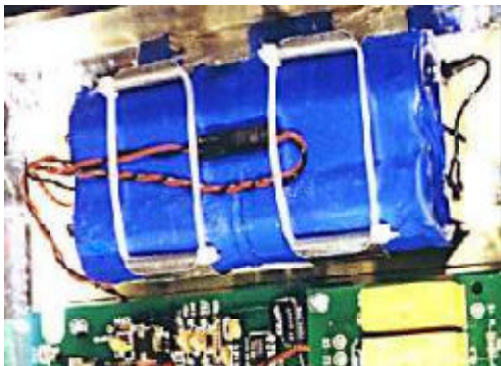

(photo shows AMPTEC 630ES battery pack)

The reliability of the 630ES battery pack is estimated to be ten fold better than individual batteries simply placed in the battery holder. AMPTEC RESEARCH does not recommend using individual NICAD batteries in lieu of the AMPTEC 630ES battery pack, and as such would be deemed a violation of product warranty. To order a replacement AMPTEC 630ES Explosive Safety Meter NICAD battery pack specify AMPTEC part number "OP630-BAT".

C-2. 630ES Test Lead and Connector Sets

All AMPTEC Explosive Safety - Igniter Tester / Failsafe Ohmmeter Test Leads and Probe sets are a minimum 48" length. One end of the test lead set is terminated with the mating connector for 630ES Front panel connection port (user specified). AMPTEC RESEARCH's website <http://www.amptec.com> should also provide the latest information on accessories available.

Option 630-300 : A 4 Terminal Kelvin Clip Lead Set (630ES compatible)



The option "630-300" is a shielded 48" lead set terminating in 1/2" opening Gold Plated 4 Terminal Kelvin clips that is AMPTEC 630ES compatible. The option "630-300" can clip easily to wires, pins, and medium size (up to 1/2" diameter) conductors. Option "630-300" is the recommended Kelvin Clip four wire lead set for the 630ES Series Igniter Testers. The notched connector end plugs directly into the 630ES's J1 main front panel connector labeled for "test leads".

Option 630-304: 4 Wire Kelvin Banana Jack Test Lead Set

Option "630-304" is recommended Kelvin four wire banana jack test lead set for the 630ES Series Igniter Testers. The option "630-304" is **terminated with four individual gold plated banana jacks** (V_{high} , V_{low} , I_{high} and I_{low}). The notched connector end plugs directly into the 630ES's J1 main front panel connector labeled for "test leads".

Option 630-305: Separate/Twin Banana Plug (Red and Black) Cable Set



Option "630-305" is a 48" long replacement cable set optionally available as an accessory for 2 wire resistance method applications, when using the AMPTEC 630ES Explosive Safety Meter.

The Option "630-305" has two single gold plated banana plugs (meter and common) terminated with the 630ES Explosive Safety Meter style notched connector (J1 mating). One banana plug is red (Voltage high and Current High) and one banana plug lead end is black (Voltage low and Current low). The back of each banana jack is open to accept any other banana post when "piggybacked" into it. **The 4-wire configuration is maintained up to the point of the banana plug, eliminating most cable resistance effects.**

Option 630-311: Reynolds Industries 311-1 Compatible Test Lead Set

The AMPTEC 630ES Explosive Safety Explosive Safety Ohmmeter / Igniter Tester is available with a connection lead adapter to the Reynolds Industries 311-1 style connector.

The option "630-311" adapter lead set is optionally available (subject to supplier *Reynolds Industries* component delivery time). The 6 feet long option "630-311" test lead set facilitates connection from the AMPTEC 630ES Front Panel to the Reynolds Industries 311-1 panel mount jack.

Option 630-Plug: For Custom Test Harnesses

Option "630-Plug" is the 630ES Test Lead Plug along with 8 gold pin/sockets for custom wiring/missile test harness applications.

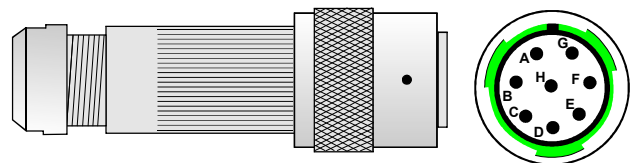

Option 630-401: Single Probe Lead Set

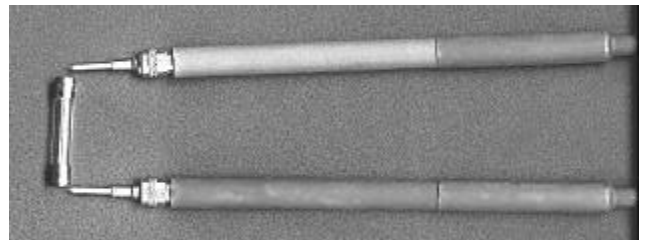

Option "630-401" is a 4-wire lead set (up to the probe tip, 2 and 2 style) terminated with single handheld probe test points. The "630-401" also has the standard 630ES Explosive Safety Meter notched test lead plug that connects directly to the main 630ES Explosive Safety Meter J1 panel mount connector. The 4-wire configuration is maintained up to the point of the probe, eliminating most cable resistance effects.

Option "630-401" handheld probes may be used where a single probe tip is a must (i.e. probing into ordnance connector sockets or difficult to connect to conductive test points).

Option 630-403: Kelvin Probe Lead Set

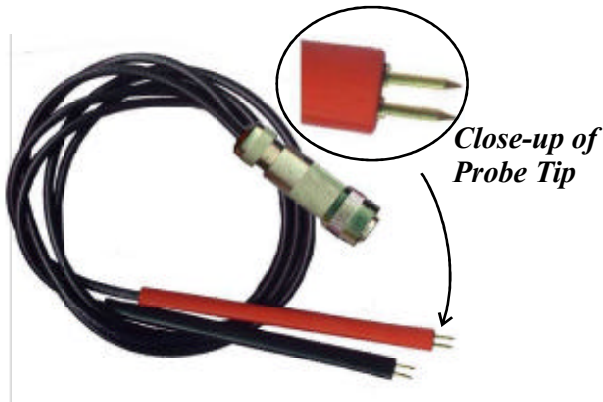

Option "630-403" is a 4-wire Kelvin Handheld Probe Lead set terminated with two handheld probes (2 gold plated spring loaded tips per probe). The "630-403" also has the standard 630ES Explosive Safety Meter notched test lead plug that connects directly to the main 630ES Explosive Safety Meter J1 panel mount connector. The 4-wire configuration is maintained up to the probe tips, eliminating all 2 wire offset errors (i.e. cable resistance).

Custom Leads and Options - Available

Contact the sales department at AMPTEC RESEARCH (phone 1-800-350-5105) if you have need for a special probe, adapter, lead set, Isolated Analog Output, Optically Isolated RS232C Serial Communications port for getting the readings to a PC, or a custom option not listed in this manual (i.e. any AMPTEC 630ES Explosive Safety Meter Test Lead requirement - Reynolds Industries 311-1 compatible connections). AMPTEC'S experienced application engineers have helped supply many customers with special igniter tester accessory requirements.

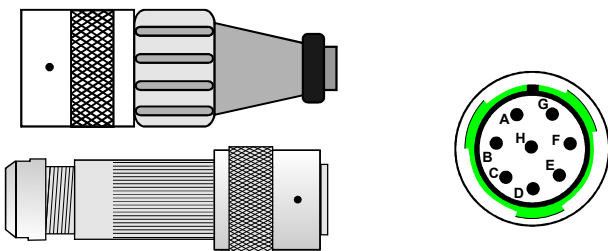

Option 630DC: Battery Charger

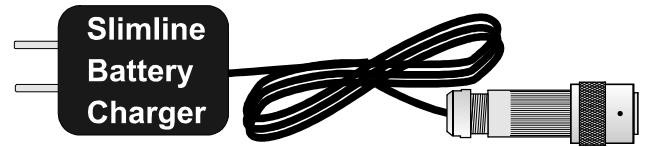

Option "630DC" is an AC/DC converter that converts 115VAC line voltage to 5.9VDC at 2.0A. The 630 Battery Charger is fitted with the mating plug that connects to the unit's J1 connector. One charger is provided as a standard accessory with every 630ES Ohmmeter. The 630ES "Connections" port does not allow the measurement test leads to be connected while the battery charger is plugged into the meters J1 connections port.

Other 630ES Compatible Leads / Adapters

AMPTEC also offers the Option "630-430" Alinco 101 Igniter Circuit Tester ringed collar connector adapter. This adapter converts the 630ES "CONNECTIONS" measurement port into the 2 wire style Alinco 101 series ring collar adapter for use with customer squib wire harnesses that were originally used with the Alinco 101 Series Igniter Tester.



SECTION D: OPERATION AND USE

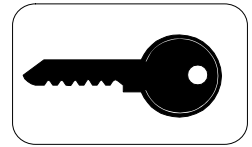

D-1. General

This section of the manual contains complete operating instructions for the AMPTEC 630ES Explosive Safety Igniter Tester/ Failsafe Ohmmeter. A description of the front panel controls, connection instructions, and the theory behind 4-wire resistance measurement is discussed in this section.

D-2. Front Panel Features and Operation

Power Switch

When the front panel power switch is placed in the OFF/CHARGE position, all power is removed from the ohmmeter measurement pins of the J1 connector (see E-6), and the battery pack is connected to the charging circuit. When the switch is placed in the ON position, the battery pack is disconnected from the charging circuit. In addition the keyed connector on the 630ES front panel **only allows either connecting** a) the battery charger **or** connecting b) the test lead set but not both. The possibility of a common mode voltage between the device under test and AC Power ground is therefore completely eliminated. The operator can not be concerned if the battery charging adapter is plugged into the 630ES as it is then impossible to make any resistance measurements.

Range Switches

The AMPTEC 630ES input range is selected by depressing the desired range switch (silicone boot coated for water resistance) on the front panel. The pushbutton for the (20 Ohm) lowest resistance range is just below the display on the left, (see item 20 of the

630ES Front Panel Diagram.). When a given range is selected an indicator LED informs the user. Also note that a resistance range must be selected after powering up the 630ES in order to place it in an operational mode.

Calibration Access Screws

Around the perimeter of the 630ES front panel you will note there are 10 screws (philips head type) that are used for calibration access. These screws are meant to remain intact and should only be removed by authorized personel (i.e. Calibration Lab staff).

Function Test Section

The Function Test Section of the 630ES contains an analog 10 mA fullscale milliammeter and a variety of test resistors. With one test lead (i.e. red banana) plugged into the meter panel jack and the other test lead (i.e. black banana lead) plugged into the common panel jack, the milliammeter will display the actual test current coming from the 630ES Igniter Tester.

The test resistors for the Function Test Section may also be used to verify general 630ES operation. Keep in mind the proper resistance range should be selected in order to measure a selected test resistor. You can't measure a 1000 ohm resistor on the 20 ohm range of the 630ES. With one test lead (i.e. red banana lead) plugged into the selected test resistor panel jack and the other test lead (i.e. black banana lead) plugged into the common panel jack, the 630ES Igniter Tester should display a resistance value close to the labeled value of the resistor. The 0.1 ohm resistor is commonly used to

test the low end (i.e. linearity) of a given 630ES resistance range. The 0.1 ohm resistor can be used to check the 630ES's zero offset. The AMPTEC 630ES's zero adjust knob can be adjusted while whilst the test leads are connected to the 0.1 ohm resistor. The 630ES zero knob can be adjusted until the 630ES display shows 0.1 ohms.

Refer the AMPTEC 630ES to qualified service personnel (i.e Calibration Lab) if you suspect (i.e large error) the 630ES measurement display readings don't agree with the resistor values labeled on 630ES Function Test Section.

AMPTEC 630ES Front Panel Diagram

1. Calibration/Maintenance access screws, also can be easily protected with a tamper

proof calibration sticker or seal.

2. Purge Valve provides air pressure equalization to open the 630ES case after a transit involving an altitude change if unit will not easily open.

3. Handles for lifting front plate, once the access screws have been removed, for calibration access

4. Single Access Multi-purpose Notched Main Connector - for *either* test lead hookup *or* connection to the battery charger. With only one connector to the outside world, it is physically *impossible* to do both at the same time. The power switch (item #21) must also be in the "Off/Charging" while the battery charger is connected to recharge the batteries.

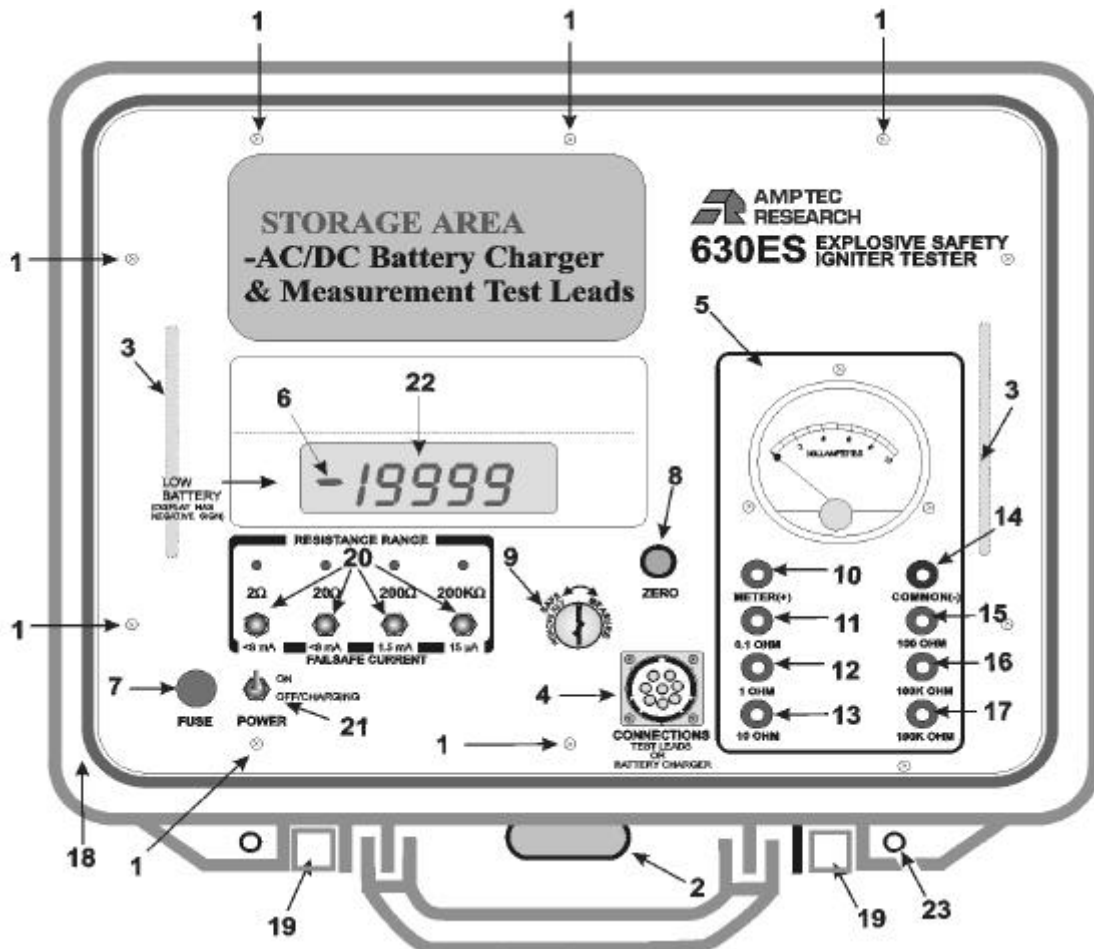

5. Milliammeter for measuring test current coming from the AMPTEC 630ES Ohmmeter. Plug one lead into the panel jack labeled “meter” and the other into the common panel jack. The Analog Milliammeter (current meter) is for measuring actual 630ES test current (0 to 10 milliamperes fullscale). Use of the milliammeter (+) panel jack and Common panel jack (-) in the *FUNCTION TEST SECTION* with the 630ES test leads provides the 630ES analog milliammeter test current measurement connection.

6. Negative sign at the front of the digital display indicates “low battery level” - time to recharge.

7. Fuse Access - required for general operation - 2 ampere slow blow type.

8. Zero pot - for adjusting the shorted resistance offset of the test lead wiring when in the 2 wire mode.

9. Keylock Switch - “Safe” mode shorts inputs together (locked “SAFE” with the key removed), disconnects & isolates any user inputs from all 630ES measurement electronics. “Measure” mode switches user test lead/inputs to the 630ES Explosive Safety Igniter Tester/Ohmmeter (*the key is required to switch 630ES to the Measure mode*) . Again, if the key is removed the 630ES cannot measure.

10. Input jack for connecting the 630ES Ohmmeter meter test lead (plug-in red banana jack) **to the analog milliammeter.**

11. Input jack of 0.1 ohm test resistor for checking the lower end or near zero accuracy of the 2 ohm and 20 ohm range.

12. 1 ohm test resistor for checking the mid-scale functionality of the 2 ohm range.

13. 10 ohm test resistor for checking the mid-scale functionality of the 20 ohm range.

14. Input jack for connecting to the 630ES **Ohmmeter common** test lead (plug-in black banana jack). This common jack is also “**Chassis Ground**”. The lining of the 630ES Explosive Safety Igniter Tester case is completely enclosed in a conductive **shielded Faraday Cage**. The AMPTEC 630ES Faraday Cage design provides additional electronic noise immunity, Electromagnetic Pulse (EMP) and Electrostatic Discharge (ESD) protection. All measurement cabling (i.e **Current** high, **Voltage** high, **Current** low, **Voltage** low) are shielded. The measurement leads **conductive shielding is all connected to Chassis Ground (Pin G of the Single Access Multipurpose Notched Main Connector and the Faraday Cage)** when the leads are connected to the AMPTEC 630ES Explosive Safety Igniter Tester. This **chassis ground common terminal** may also be connected to earth ground at the users discretion. Chassis Grounding the 630ES eliminates the possibility of an electrostatic discharge coming from the 630ES to the resistance device under test.

15. 100 ohm test resistor for checking the functionality of the 200 ohm range.

16. 100K ohm test resistor for checking the functionality of the 200K ohm range.

17. 190K ohm test resistor - if shunted in parallel during an “Open Circuit” test using the 200 K ohm range, a shift < 40 counts means the resistance under test is >200 Megohms.

18. Water Resistant O-ring seal(s) in lid and under the edge of the front plate.

19. Tight Squeeze Flip Latch Area - provides a water resistant seal when closed. While pressing down with palm on corner of case, flip latch up to open.

20. Resistance Ranges - 2 ohm, 20 ohm, 200 ohm and 200K ohm - silicone boots provide water-resistance (small LED indicates the selected range).

21. Power “On or OFF/Charging Switch”

22. Beveled Display Hood and Super Bright LED Display (five times brighter than bright yellow, red or green LEDs).

23. Padlock Hole (i.e. security) while stored or during transit.

D-3. Fuseholder and Charging System

Fuseholder

The fuseholder is mounted on the front panel and contains a 2 amp in-line fuse (see item 7 of the 630ES Front Panel Diagram.). This fuse is designed to protect the internal battery pack from excessive charging currents. Replace blown fuses with the same type and rating only!

The Charging System

The slimline AC to DC battery charger with connector is a notched connector that mates with only two of the 8 pin/socket mating points on the main panel mount connector (see Main Connector J1 Section E6 for pinout definitions). The connection is made on the 630ES front panel (see item 4 of the 630ES Front Panel Diagram shown earlier).

Again the **Single Access Multipurpose Notched Main Connector** is for *either* test lead hookup *or* connection to the battery charger but not both at the same time. ***With only one connector to the outside world***, it is physically ***impossible*** to do both at the same time (charge and measure). The power switch (item #21) must also be in the “Off/Charging” mode while the battery charger is connected in order to recharge the batteries. The charging requirements supplied to the internal battery pack are

internally stepped down from the 5.9VDC @2.0A supplied by the charger. The correct charging voltage is supplied by the adapter included with the instrument. Additional AC/DC Battery Chargers are available as Option "630DC". Typically an overnight charge (16 hours) will provide about an 6 to 8 hour continuous powered up life for the 630ES. The 630ES have an internal ovenized voltage reference the draws a considerable amount of battery power when first turned on. If you know you will be using the 630ES again in 10 to 15 minutes, you actually conserve battery power by not turning it off.

D-4. 4-Wire Resistance Measurement

The four-terminal configuration of the 630ES eliminates errors normally caused by in series test lead resistance and contact resistances. In many applications the contact resistance and can exceed the value of the test resistance by several orders of magnitude. The 630ES overcomes this potential error source by providing two terminals of constant current and an additional two terminals for high impedance voltage measurement. The result is a fast, accurate resistance measurement of the test resistance, independent of the resistance of the current carrying leads.

Figure D-1 (below) illustrates how the 4-wire principle is used to eliminate lead, wire and contact resistances as potential error sources. The internal current source inherently overcomes all series resistance (within compliance voltage limits) and delivers a precise constant current. The internal high-impedance DVM senses the voltage drop across the test resistance. There is negligible contact and lead resistance error created by the voltage measurement because the high input impedance of the DVM limits current flow in the voltage leads.

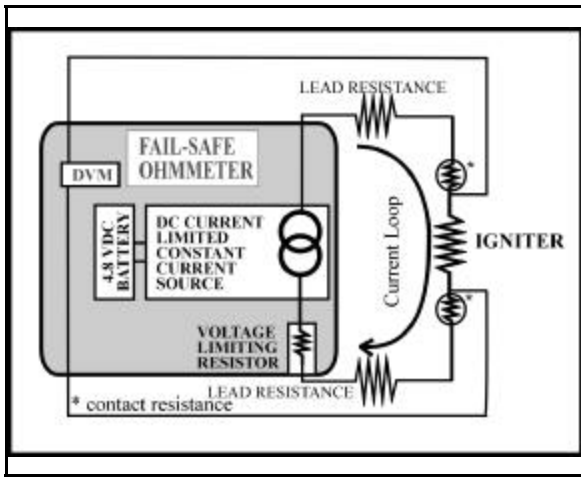

Figure D-1. Error Sources in Resistance Measurements eliminated with Four Wire Kelvin Connections

D-5. Connections

Connections are made to the front panel terminals using a 4-wire configuration as described in section D-4. Only use AMPTEC test leads supplied with the 630ES Failsafe Ohmmeter. When using AMPTEC test leads, the notched connector end plugs directly into the single access notched main connector (see J1 manual section E-6) of the 630ES. ***Next turn the connector clockwise until you feel the notch or click of the mating connector of the 630ES.*** All AMPTEC 630ES leads have the 4 wire current high, current low as well as the voltage sense high and voltage sense low routed to the end of the leads. The 4 wire Kelvin wires then terminate in a pair of single banana plugs. One banana plug (**red**) for current and voltage high, and another banana plug (**black**) for current and voltage low.

The 630ES's keyed single access connector also make it extremely difficult if not virtually impossible during normal operation to mis-connect measurement leads to the 630ES .

For 630ES leads other than those terminated with banana plugs, RG-58 Coax Cabling is used. This insures that using the four wire Kelvin measurement system - the current is carried in the largest conductor and that the voltage input is shielded.

In addition, the 630ES keyed test lead connector is optionally available for customized wiring connections , kelvin clips, cables terminated with spade lugs, and special banana jacks.

All AMPTEC ohmmeters use a high impedance voltmeter as part of the resistance measurement process. This voltmeter is a highly accurate and stable 4½ digit analog-to-digital converter (A to D). Unless it is receiving a definite input signal, the output reading of this A to D is ambiguous. The display may indicate a randomly wandering number or it may indicate an overrange condition. This unpredictable display may make it seem to appear that the instrument is experiencing some sort of malfunction. It is, in fact, just a characteristic of the voltmeter circuit and should not be mistaken for a fault in the instrument.

A flashing display (on and off usually all zeros) indicates an over-range condition whenever the terminals are open, or the resistance under test is a higher value than the selected 630ES resistance range. By using a 4-wire Kelvin type lead set or by shorting the V_{HI} and I_{HI} terminals together and V_{LOW} and I_{LOW} terminals together the instrument is in the 2 wire resistance mode.

All wiring including harness wires from the two wire test connection out - are in series with the test squib resistance and become part of the actual two wire measurement (***another potential source of measurement error if not compensated for***) . Many Ordnance test procedures have the 630ES user short their wiring harnesses at the very end (by the squib) and record the resistance

value or offset. Then when the 630ES leads, including the in-series harness wiring resistance, is connected to the test squib, the squib test resistance can be calculated (via subtraction of the 2 wire harness offset). That is the 2 wire lead length shorted offset resistance (without the squib resistance) can be subtracted for the total resistance (including the squib resistance) to determine the actual squib (test) resistance.

The display should indicate a stable reading when the test leads are securely attached to the device under test. If the display appears to be erroneous when connected to the resistance under test, recheck the test leads for integrity and cleanliness. If all external items appear to be functioning properly, the next step in troubleshooting is to use the **Function Test Section** of the AMPTEC 630 series igniter tester. The Functional Test section contains test resistors of known value. If a measurement problem appears on the 20 Ohm range of the meter, test for a zero offset problem first. Plug the test leads into the 0.10 test resistor banana panel jack built into the Functional Test Section of the meter. If the meter doesn't display a value close to 0.1 Ohms adjust the zero knob on the front of the meter until it does. The zero adjustment knob only has enough span to zero out the 630 series test leads. The meter's zero adjustment knob wasn't designed to zero out a 100 feet of 2 wire harnessing.

The 10.0 Ohm test resistor is also located **Functional Test Section** of the meter. The 10.0 Ohm test resistor can be used for testing mid-scale performance of the 20 Ohm range. Performing a similar Functional Test with the meter across the 10.0 Ohm test resistor should get a reading close to 10.0 Ohms (i.e. **9.995** Ohms is OK). If the 630 series Igniter Tester appears OK after checking the test resistors in the **Functional Test Section** then the connection problem must be outside of the 630 series meter (i.e. your wiring harness or the actual device

under test connection.) If the 630 series meter doesn't agree with the test resistors in the **Functional Test Section**, then the meter or its test leads are most likely broken. If this case, please contact your local AMPTEC RESEARCH Service Office, or call 1-800-350-5105 or (512) 301-9333 (International Overseas) or FAX (512) 301-9303, email service@amptec.com.

D-6. Failsafe Operation

The AMPTEC 630 series of igniter testers or failsafe ohmmeters incorporate a **constant current source design** that renders them incapable of delivering excessive voltage or current to the device under test. The *typical* fail-safe current for each range is indicated under the corresponding range switch on the 630 series meter front panel. Please refer to section E-6 for a technical description of the failsafe circuitry specifics.

As a further precaution the 630 series igniter tester is isolated from the AC line whenever the POWER switch is in the ON position.

The 630 series igniter tester receives its power from an internal rechargeable battery pack (4 "D" Cell Ni-Cad batteries). The 630 series igniter tester main power switch (see item 21 of the 630 series igniter tester Front Panel Diagram) must be in the OFF / CHARGING position in order to charge the batteries. Of course, the battery charger must also be plugged into the unit's keyed single access connector. As mentioned earlier the 630 series igniter tester's keyed single access **front panel connector allows either** the slim-line battery charger to be connected **or** the 630 series igniter tester test leads to be connected to the 630 series igniter tester ohmmeter **but never both simultaneously**. This "keyed single access front panel connector" **safety feature** eliminates any possibility of the operator measuring with the 630ES Igniter Tester test leads while also connected to an AC line powered adapter.

D-7. Battery Monitoring Circuitry

The 630 series igniter tester display has a \pm polarity display indicator preceding the unit's regular 4 ½ digit numeric display. The negative polarity display LED (see item 6 of the 630 series igniter tester Front Panel Diagram) is used as a Low Battery indicator.

If the low battery LED is illuminated, 630ES readings should not be trusted. An overnight recharge should be performed before using the 630 series igniter tester for critical testing.

It is possible for the user to receive a low battery indication on a single range only (particularly the 20 ohm range), while the 630 series igniter tester remains well within operating limits on other ranges. **Unless the user observes a continuous low battery indication during measurement, readings are still valid.**

Notice for Cal Lab: The variable potentiometer - RV3 is factory adjusted to have the low battery indicator come on at 4.50 VDC. To make this adjustment, and **remove the fuse** from the fuseholder. With an adjustable DC power supply, set the power supply output to be 4.50 VDC. Be sure to observe power supply polarity. Connect the power supply to the test points labeled "MAIN" + pos. and - neg. located in the rear section of the 620A MAIN PCB. (i.e positive + power supply output to the anode side). Adjust trimpot RV3 to have the low battery indicator just come on (negative sign on display). An increase in power supply voltage to 4.52 VDC should have the low battery indicator go out. Finally, disconnect the power supply, and return the fuse to the fuse holder in the rear panel.

D-8 Zero Pot

The Zero Pot on the 630 series igniter tester Front panel (see item #8 on 630 series

igniter tester Front Panel Diagram) is used to adjust linearity, which effectively adjusts the "zero" of the meter. The zero can be adjusted using the "zero knob" per the maintenance section of this manual. The zero knob can also be used to counteract the 2 wire resistance offset encountered with some test lead harnesses. Checking the 630ES "zero offset" should be one of the first items a user does if one encounters an unusual or unexpected resistance level.



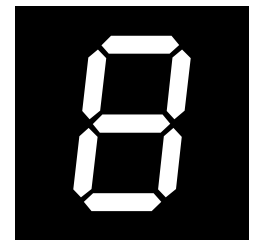

E-1. General

The AMPTEC RESEARCH 630ES Igniter Tester is shown in block diagram form in Figure E-1. All diagrams and information disclosed in this chapter is proprietary and is included in order to make troubleshooting to component level possible.

The AMPTEC 630 Series Igniter Tester uses modern solid-state semiconductors exclusively and digital CMOS circuits extensively to minimize power requirements and make battery operation useful and practical. AMPTEC also maintains a spare parts inventory of all components found in the 630 tester and it's customer service department can also provide additional assistance in the trouble shooting process.

E-2. Troubleshooting

Since the 630 Tester is used to test potential deadly explosive force detonators and warheads of missiles etc., ***personnel that are not qualified to make such electrical repairs on the 630 Tester should not even attempt to remove the calibration access screws or open the main panel or effect any repair whatsoever.***

Apparent 630 Tester malfunctions can sometimes be the result of bad test lead/connection wiring, wrong connections, misinterpretation of specifications, low battery levels, and in rare cases due to an incomplete understanding of the instrument and how to use it. A thorough review of the operating instructions for this instrument is recommended prior to any component replacement. Check to be sure that cables and other test equipment are in good working order before attempting to troubleshoot the 630 series igniter tester .

If you turn on the AMPTEC 630BN, and the display does not come on, it may indicate the batteries need charging, or fuse needs replacing.

If the 630ES exhibits problems that cannot be eliminated by reviewing Chapters B and D, the following guidelines have been established to help solve the problem.

E-2-1. Localizing the Problem

Chapter D-2 discusses how to use the ***Functional Test Section*** of the 630 Tester to help localize the problem. The key to successful troubleshooting is to localize the problem to a general electronic parameter as much as possible before trying to pin the problem down to a specific component. Certain questions should be asked such as "Does the problem occur on all ranges or on a specific range only?". If the 630 Tester does not come on when powered up, did you check the front panel fuse. The power supplies for both the current source and the digital voltmeter electronics are also one of the first things that should be tested.

As it is not possible to anticipate all failure modes of the 630 series igniter tester, servicing personnel should become familiar with this section to gain a complete understanding of the internal workings of the ohmmeter.

E-2-2. Component Replacement

If the malfunction is a faulty component, the accuracy of the 630 series igniter tester can be maintained only if the 630 is re-calibrated following the component replacement and the following precautions are taken:

Use only the specified component or its exact equivalent. Spare parts can be ordered from your nearest AMPTEC RESEARCH Service Center or directly from the factory by referring to the AMPTEC Stock Number listed in the Parts Lists section at the back of this manual.

The highest quality 63/37 grade rosin core electronic grade solder with a 50W or lower maximum power soldering iron should be used. Never use an acid core solder as corrosion of components leads and PCB etch loss can occur.

When soldering, heat the PCB pad and the lead of the component, not the solder. After several seconds of the component lead in contact with the hot soldering iron apply solder smoothly and evenly onto the PCB pad and component lead not the soldering iron. Do not touch or move the replacement part until the solder has cooled. Cold solder and bad solder joints can cause more problems.

Use the chassis ground (connect to the common terminal of the functional test section) connection - i.e. connect to an earth ground to avoid a static discharge to a static sensitive component. Handle all 630 internal components as if they are static sensitive if you are not sure.

See Next Page for Start of 630 Circuit Descriptions and Functional Diagrams

E-3. Circuit Descriptions

The circuit descriptions which follow are referenced to Figures E-1, E-2, E-3 and the schematic diagrams at the back of this manual. In the following descriptions, references to integrated circuits are given in the form "IC201-1", which refers to Integrated Circuit 201, pin 1.

E-4. Analog to Digital Conversion

The A to D conversion is done with a ICL8068 /ICL71C03 chip set. The ICL8068 takes care of the analog part and the ICL71C03 takes care of the digital part of the 4 ½ digit 20,000 count dual slope conversion.

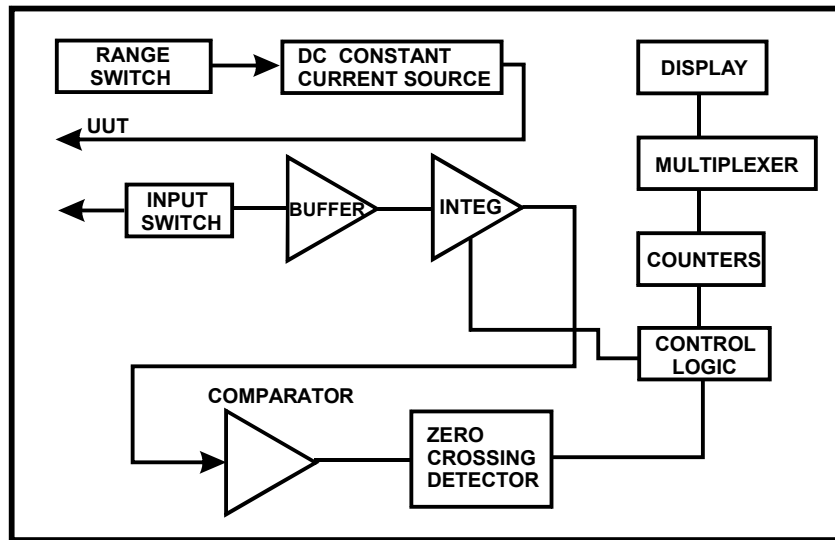

MODEL 630ES OHMMETER BLOCK DIAGRAM

| COUNTS | | | |
|-----------|---------|----------|-----------|
| | PHASE I | PHASE II | PHASE III |
| 4 ½ DIGIT | 10.001 | 10.000 | 20.001 |

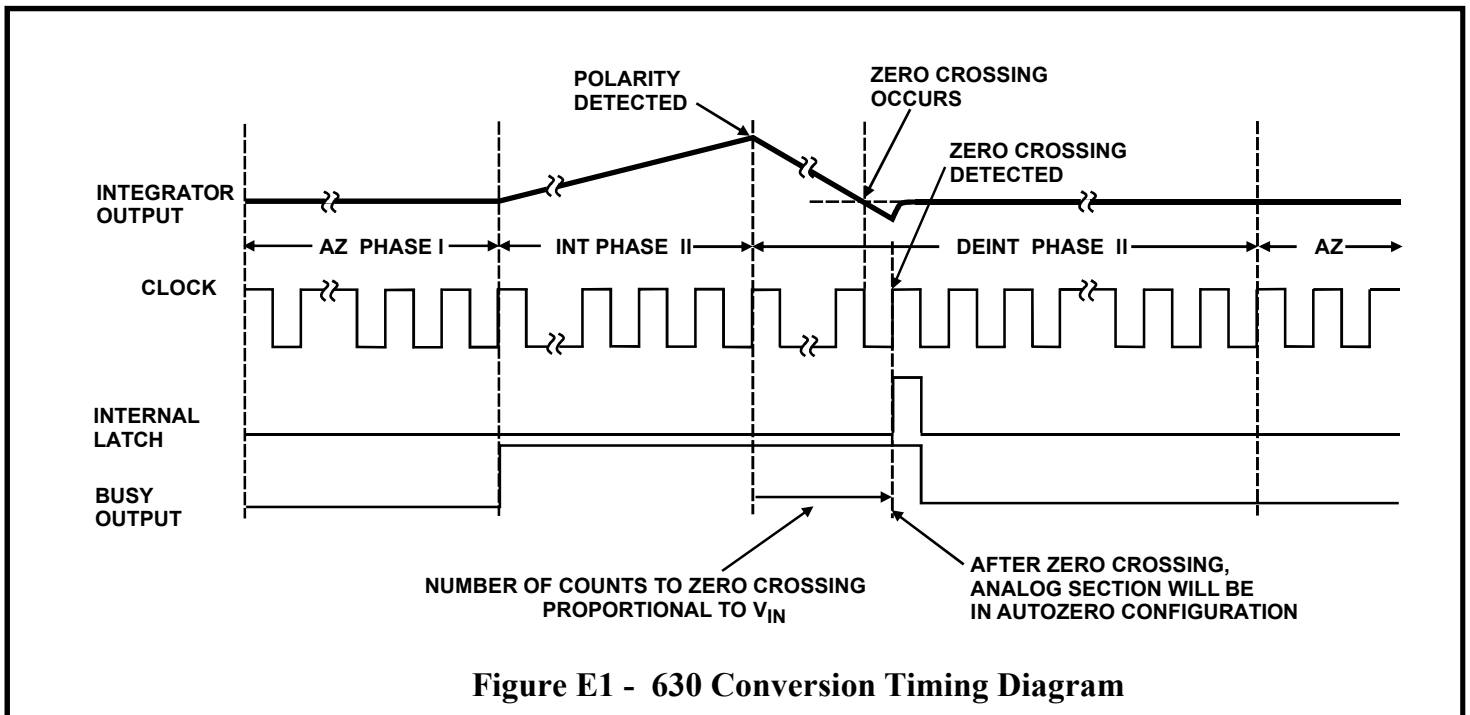
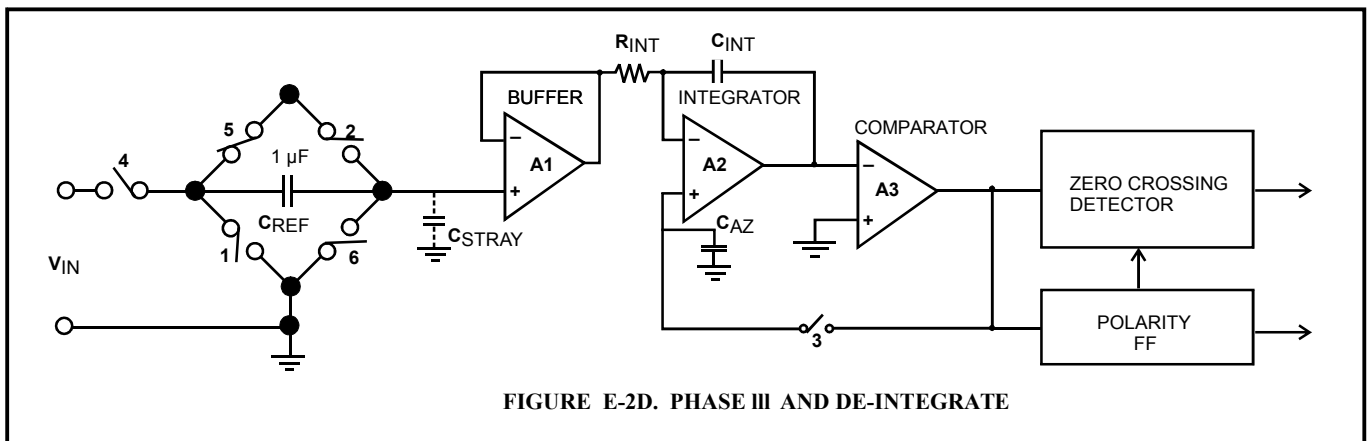
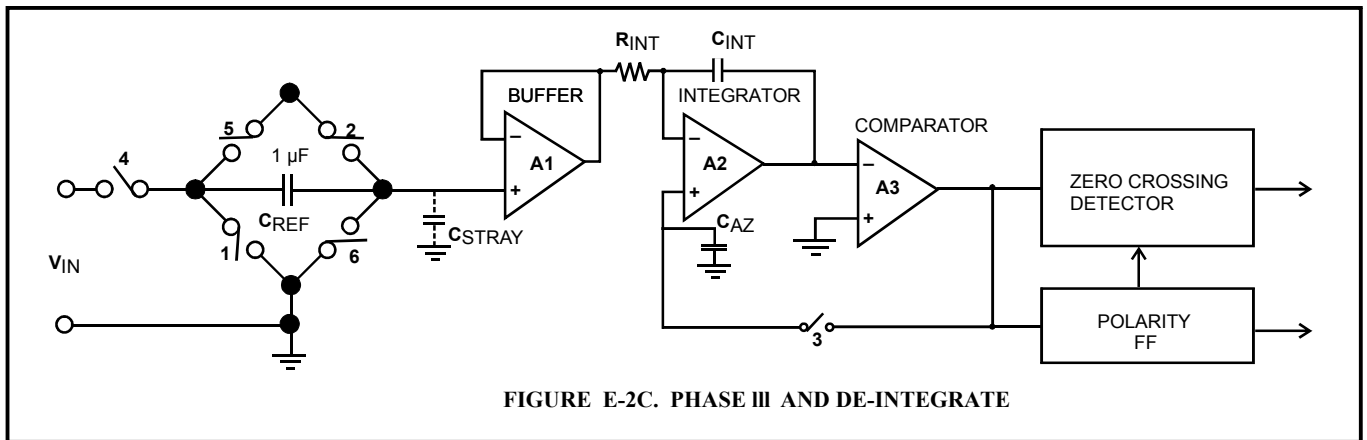
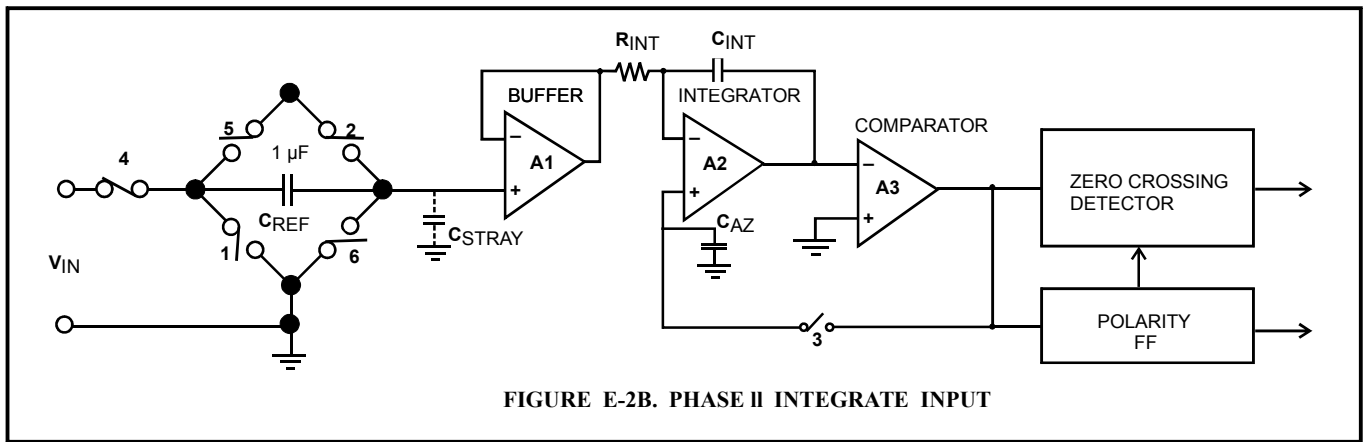
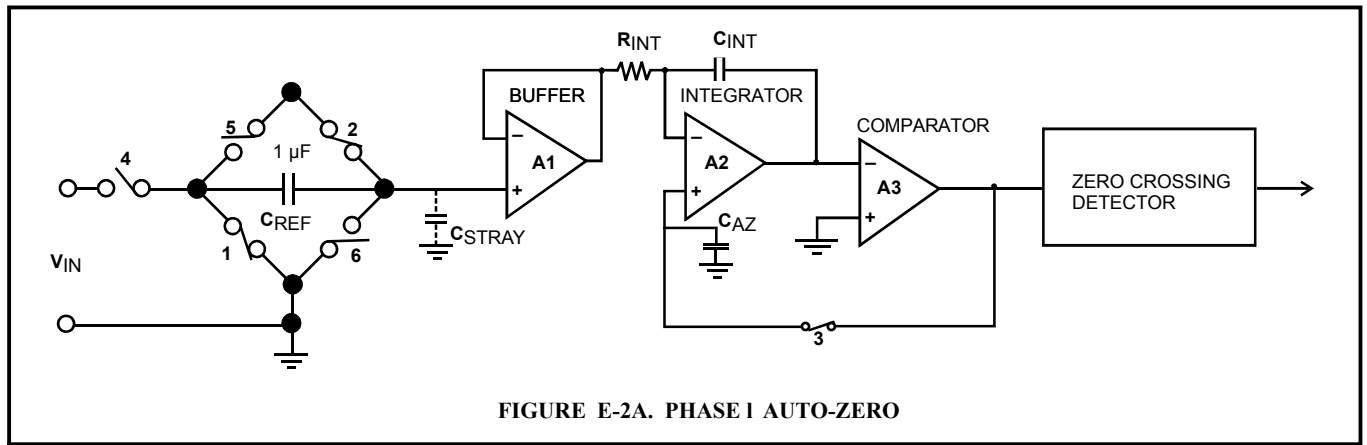

Figure E1 - 630 Conversion Timing Diagram



Figures E2. Main Analog Section of DVM Circuit - IC1 and IC2

Detailed Description

Analog Section

Figures E2 diagrams A thru D shows the equivalent circuit of the analog section in 3 different phases of operation. The system will perform conversions at a rate determined by the clock frequency 40,002 clock periods per cycle. (see Figure E1B shown earlier in this chapter for details of conversion timing).

Auto-Zero Phase I (Figure E2A)

During the Auto-Zero, the input of the buffer is connected to V_{REF} through switch 2, and switch 3 closes a loop around the integrator and comparator, the purpose of which is to charge the Auto-Zero capacitor until the integrator output does not change with time. Also, switches 1 and 2 recharge the reference capacitor to V_{REF} .

Input Integrate Phase II (Figure E2B)

During Input Integrate the Auto-Zero loop is opened and the Analog Input is connected to the Buffer Input through switch 4 and C_{REF} if the input signal is zero, the buffer, integrator and comparator will see the same voltage that existed in the previous state (Auto-Zero). Thus, the integrator output will not change but will remain stationary during the entire input integrate cycle. If V_{IN} is not equal to zero, and an unbalanced condition exists compared to the Auto-Zero Phase, the integrator will generate a ramp whose slope is proportional to V_{IN} .

Deintegrate Phase II (Figures E2C and Figures E2D)

During the Deintegrate phase, switch 5 is closed and a voltage which is V_{REF} more positive than during Auto-Zero is impressed on the BUFFER INPUT. Thus the reference capacitor stores the equivalent voltage. This returns the output of the integrator to the zero crossing point established in Phase I. The time, or number of counts, required to do this is proportional to the input voltage.

E-4-1. Reference Voltage

The precision reference voltage required to do the A/D conversion is developed by IC201. The zener voltage is attenuated to approximately -0.5V. This voltage is applied to IC2-7.

E-4-2. LED Display

The output format from IC2 is in Binary Coded Decimal (BCD) format. Each digit is scanned for 10 clock pulses. The scan sequence is D5 D4 D3 D2 D1. This drives Q1 thru Q5, which in turn drives the seven segment displays. The BCD data is converted to seven segment format by IC4. When the 630BN electronics are in open circuit or over-range mode the display flashes "0000". IC5 is a 1 MHz oscillator which is divided by 10 by IC6. The 100 KHz clock output then goes to IC2.

E-5. Ohms-To-DC Converter

The ohms-to-DC converter generates a constant current which is passed through the device under test to develop the voltage measured by the A/D converter.

E-5-1. Constant Current Source

The constant current source is composed of IC201, IC202, Q202, D203 and their associated components. The input to the constant current source is approximately +1.05 volts, developed at IC201-7 and connected to IC201-13 through R209 and R210. The heart of the constant current source is the voltage-to-current converter. A simplified schematic of this circuit is shown in Figure E-4 and described in Section E-5-2. The amplifier of IC201-12 is an inverter, and its output is applied to IC201-9. The amplifier of IC201-8 has unity gain due to the feedback through R213. Its output is applied to the inverting input of IC202-3. The output of IC202-6 provides feedback to the non-inverting input of IC201-10. This circuit operates to maintain the inverting input at IC202-3 and the non-inverting input at IC202-2 at the same potential.

E-5-2 Constant Current Circuit Operation

Assume that terminals I_{hi} and I_{lo} of Figure E-3 are shorted, and 1 volt is applied to E_{in} so that I_{hi} is positive. To equalize the 1 volt applied to E_{in} , the inputs of IC202, IC201 must be driven to zero. This condition occurs only when the voltage drops across R212 and R222 are equal to the drops across R213 and R221. For these voltage drops to be equal, the output of IC202 must be at +1 volt. Since the output of IC201-8 must be zero, the drop across R213 is 0.5 volts, making the inverting input 0.5 volts. The drops across R212, R221 and R222 will also be 0.5 volts. Since the inputs to IC201 are essentially equal, its output is zero (offset by the few microvolts required to drive IC202 to +1 volt). Under these conditions the sum of the voltages across R212, R213, R221 and R222 equals the sum of E_{in} plus the output of IC202.

Consider now that the short is removed from the I_{hi} and I_{lo} terminals and a 100-ohm resistor (R_L) is connected in its place. The current through R_L increases the voltage at the input to IC201. A balanced condition will be reached when the output of IC201 is equal to the non-inverting input of IC202. Again, this condition occurs when the voltage drops across R212 and R222 are equal to the voltage drops across R213 and R221. At this time the output of IC202 is 1.1 volts. The voltage drop across the range resistor is 1 volt, just as it was when the output terminals were shorted. The current through R_L is 10 milliamperes, just as it was through the jumper when the output terminals were shorted.

E-6. Failsafe Design

Reference to the AMPTEC 630 Tester Igniter Tester schematic will show that the output of IC202-6 is actually applied to the base of transistor Q202, *which acts as a current limiter. The worst-case component failure that could occur in this circuit would be a Q202 short*, which would effectively connect the -5 volt supply directly across R218, D202, the range resistor and R_L .

D203, however, acts as a 1.6 volt zener diode, limiting the voltage that can appear across these components. Even if every component in the amplifier circuit shorted, the current through the

igniter could not exceed safe limits, because the -5 volt and +5V supplies includes inherent current limiting. Because of the design of both supply isolation transformers T101 and T102, the ± 5 volt supplies can only deliver 20 to 25 milliamperes before the DC/DC converter disengages, dropping the -5 volt output to zero. See Section D-7.

“J1” 630 Series Main Connection Jack

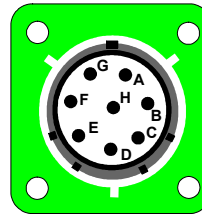

CONNECTIONS
TEST LEADS
OR
BATTERY CHARGER

| | |
|-----------|--|
| A= I High | E= |
| B= V High | F= Ground (- neg Battery Charger) |
| C= V Low | G=Chassis Ground |
| D= I Low | H= +5 V (Battery Charger)diode protected |

The AMPTEC 630 Testers are powered by a rechargeable internal battery pack and cannot be operated directly from the battery charging adapter. This is to *eliminate the possibility* of an electrical short to/from the AC line. *Only when* the 630 POWER switch is in the “OFF/CHARGING” position are the batteries are connected to only 2 of the possible 8 pin/socket contacts of the “Connections” panel mounted connector on the front panel to allow for recharge (see J1 Connections diagram in section E-6 of this manual). *For safety reasons, none of the test lead connections (outside pins A thru D) can ever make the pin-socket contact with center Pin H*. If for some reason, an abusive 630 Tester user tried physically jaming the test lead connection onto the J1 connector (i.e with a hammer) it is vitually *physically impossible due to the inner and outer align ring and drop into sleeve construction of J1*. So even if this impossible connection did some how occur, and make contact with pin H, remember all battery wiring is disconnected from the Main Connection Jack “J1” if the AMPTEC 630 Tester is turned ON. *When the POWER switch is in the ON position*, the batteries are disconnected from the battery charger and connected to the internal circuits of the AMPTEC 630 Igniter Tester.

The 630ES Tester measurement circuitry is also failsafe current limited, even under worst case component failure. **A simple startup test procedure which also has the 630 Tester user perform a functional check using the milliammeter would also detect any current level even getting close to the Failsafe level.**

For the 630ES Tester the normal or typical operating current level is less than 5 mA, and <10mA on most 20 ohm range versions as a Failsafe Level .

E-7 . Ultra-Safe Power Supply Scheme

The +5 volt power supply is provided directly by the batteries (for driving the LED displays and digital logic). The $\pm 5V_D$ is used for driving IC8, the low battery detection circuit. The $\pm 15V$ power supply is generated by IC7 for the digital voltmeter (DVM) chip set (IC1 and IC2).

The $\pm 5 VA$ is developed by one DC to DC convertor circuitry: composed of Q103, Q104, T102, D103, D104, IC102 for the negative polarity. The other DC/DC convertor is composed is composed of Q101, Q102, T101, D101, D102 and IC101 for the positive polarity.

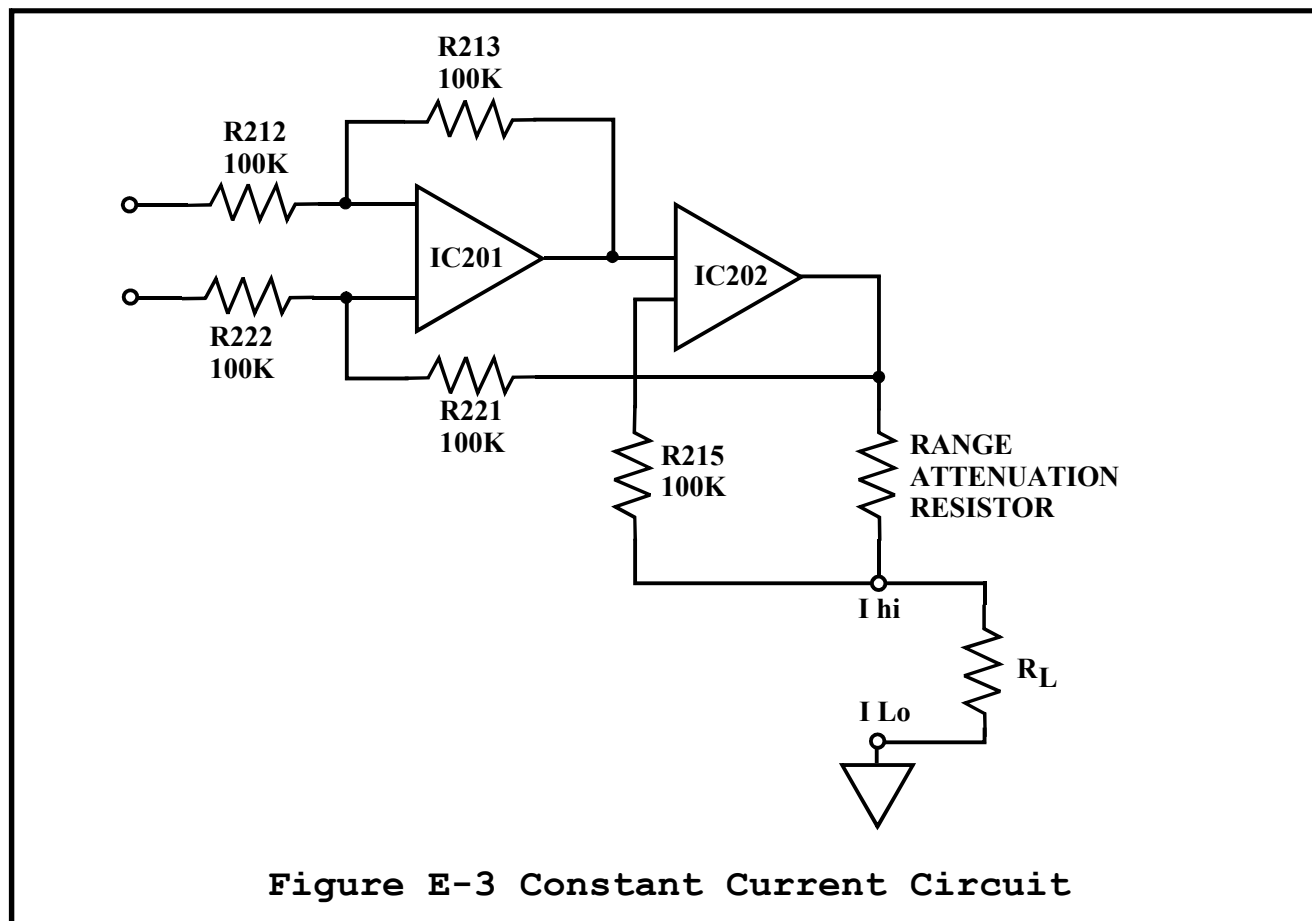

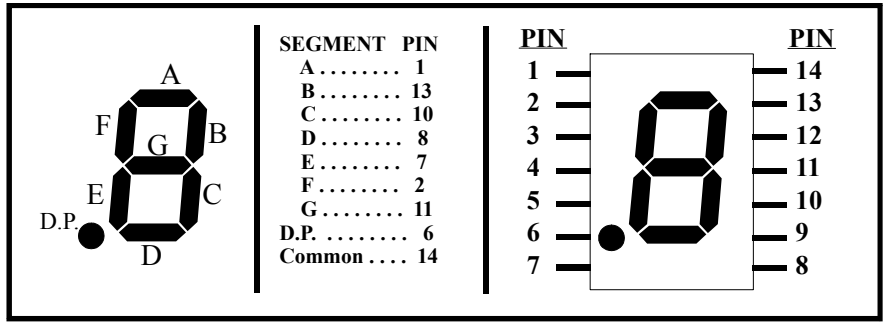

Figure E-4. LED Display Pin Functions

E-8. Relay Board General Operation

The internal 630ES PCB labeled “620-relay board” replaces the range switch S1 on the main board. IC-1 is actually a ribbon cable header that goes to the top panel and connects to the range push buttons (covered by silicone rubber boots) and their corresponding panel mount LEDs. IC-2 is a latch that will latch its output to the corresponding range push button input. Its output turns on the front panel LED (acts as an range mode indicator LED) and a corresponding relay that connects to the main PCB to select the range. RL1 is for the 20-Ohm range, RL2 is for the 200-Ohm range, RL3 is for the 2K Ohm range, and RL4 is for the 200K Ohm range.



SECTION F ROUTINE MAINTENANCE

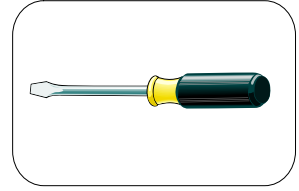

F-1. General

This section of the manual contains routine maintenance information regarding the AMPTEC RESEARCH Model 630 series igniter tester. Calibration should be performed on a regular basis to ensure continued instrument accuracy. The recommended calibration interval is 1 year.

The AMPTEC 630 series igniter tester is a four wire Kelvin ohmmeter. *The 630 series igniter tester must be calibrated using four wire Kelvin connections to the resistance standard* in order to eliminate lead resistance and contact resistance errors. The Option "630-305 twin single banana jack test leads are **not recommended** for the calibration/adjustment of the AMPTEC 630ES Safety Tester (As they are two wire type test leads with some inherent in-series resistance offset/error.) Typically 2mW of in series resistance is associated with the AMPTEC "OP630-305" two single banana lead set. 4-wire configuration is important (**AMPTEC Option 630-304"**) is the recommended test lead set to use for calibration of the AMPTEC 630ES. Therefore the option "630-305" a 48" long is **not recommended** for the calibration of the AMPTEC 630ES as it may have too much resistance offset for the actual calibration of the 630ES Igniter Tester only for the low 2.0 Ohm range. Contact AMPTEC for information on the "OP630-304 or "OP630-300" 48" long 4 wire Kelvin Calibration Lead Set all terminated with single banana jacks.

F-2. Required Test Equipment

Following standard resistors are required to calibrate the 630ES Igniter Tester .

Precision Resistors:

- 0.1 ohm \pm 0.01% Accuracy
- 1 ohm \pm 0.005% Accuracy
- 10 ohms \pm 0.005% Accuracy
- 100 ohms \pm 0.005% Accuracy
- 100000 ohms \pm 0.005% Accuracy

Test Leads:

- 4-wire lead set or
(AMPTEC Option "630-304")

F-3. Calibration Procedure

The 630 series igniter tester should be calibrated with fully charged batteries and should be allowed to **warm-up** for a minimum of **5 minutes** before beginning the procedure. The calibration adjustments are accessed by removing the 10 calibration access screws around the perimeter of the 630 series igniter tester front panel, then lifting off the top plate by the handles. The locations of the adjustments are shown on drawing number 630ES-600 .

F-3-1. Zero Offset Adjustment

1. Select the 200 ohm range. Connect the Kelvin clips to the 0.1 ohm standard resistor.
2. Adjust potentiometer RV2 (**front panel zero knob**) for a display indication of 00.10.

F-3-2. Full Scale Adjustment

1. Select the 200 ohm range. Connect the Kelvin clips to the 100 ohm standard resistor.
2. Adjust RV1 for a display indication of 100.00.
3. Check all remaining ranges with the appropriate standard resistors. All ranges must be within the specifications outlined in Section B.
- 2) Locate and unscrew the battery retaining plate on the bottom of the 630 series igniter tester (next to the main PCB).
- 3) Remove the old batteries and replace. **Observe polarity!**
- 4) Secure the new batteries in place by re-connecting the battery retaining plate.
- 5) Replace the 630ES igniter tester front panel top plate and re-tighten the calibration access screws, taking care not to pinch any wiring.

F-4. Battery Replacement Instructions

The rechargeable NICAD batteries (D cell 5.0 AHr each) used in the 630 series igniter tester are durable and should provide years of trouble-free operation. Some military maintenance procedures may require replacement of the 630ES NICAD batteries as part of the overall annual calibration plan, even if the batteries are working well. As with all batteries, replacement will eventually be necessary. Batteries may be ordered from AMPTEC RESEARCH as stock #05-10117, quantity: (4). The process of battery replacement is described below:

- 1) Remove the calibration access screws (10 of them) located around the perimeter of the 630 series igniter tester front panel. **Carefully** lift off the 630 series igniter tester front panel top plate by the handles. Note: ~16" of umbilical wire cabling connects the top plate electronics to the main PCB inside the bottom of the 630 series igniter tester case. Delicately place the 630 series igniter tester front panel - top plate (face side up) on the work bench next to the 630 series igniter tester

Low Battery Indicator:

The variable potentiometer - trimpot RV3 is factory adjusted to have the low battery indicator come on at 4.50 VDC. To make this adjustment, and **remove the fuse** from the fuseholder. With an adjustable DC power supply, set the power supply output to be 4.50 VDC. Be sure to observe power supply polarity. Connect the power supply to the wiring labeled "MAIN" + pos. and - neg. located in the rear section of the 620A MAIN PCB. (i.e positive + power supply output to the anode side). Adjust trimpot RV3 to have the low battery indicator just come on (negative sign on display) with 4.50 VDC applied from the power supply. An increase in power supply voltage to 4.52 VDC should have the low battery indicator go out. At this point the 630 series igniter tester low battery indicator adjustment should be complete.

Finally, disconnect the power supply, and return the fuse to the fuse holder in the rear panel.